



**GROUP OF TESTING LABORATORIES
GRYFITLAB**

ul. Prosta 2, Łozienica, 72-100 Goleniów
phone (091) 431 82 29, fax (091) 418 97 57, mobile:+48 607-900-483
www.gryfitlab.com, e-mail: contact@gryfitlab.com

Fire resistance classification No. LBO – 061 – KZ/20E

Classified product:

**High walls, with steel frameworks and lining made of gypsum
plasterboards manufactured by NORGIPS Sp. z o.o.**

Sponsor:

Norgips Sp. z o.o.
ul. Raclawicka 93
02-634 Warszawa

Prepared by:

Group of Testing Laboratories Gryfitlab
ul. Prosta 2, Łozienica
72-100 Goleniów

Place and date of issue:

Łozienica, 31.12.2020

Copy No. 1

The classification was printed in 3 copies. Copies Nos. 1, 2 – for the Sponsor, Copy No. 3 – AA

1. This classification has been prepared based on the following documents:

- 1.1. Standard PN-EN 1364-1:2015-08 Fire resistance tests for non-loadbearing elements – Part 1: Walls.
- 1.2. Standard PN-EN 1363-1:2020-07 Fire resistance tests – Part 1: General requirements.
- 1.3. Standard PN-EN 13501-2:2016-07 Fire classification of construction products and building elements – Part 2: Classification using data from fire resistance tests, excluding ventilation services.
- 1.4. Standard PN-EN 13279-1:2009 Gypsum binders and gypsum plasters – Part 1: Definitions and requirements.
- 1.5. Standard PN-EN 13963:2014-10 Jointing materials for gypsum boards. Definitions, requirements and test methods.
- 1.6. Standard PN-EN 14566+A1:2012. Mechanical fasteners for gypsum plasterboard systems. Definitions, requirements and test methods.
- 1.7. Standard PN-EN 14195:2015-02 Metal framing components for gypsum board systems. Definitions, requirements and test methods.
- 1.8. Report No. LP01-06041/14/R21NP regarding fire resistance tests of a non-loadbearing wall with the framework made of doubled steel profiles CW 100 placed every 600 mm, with double sided lining made of 3 x 12.5 mm gypsum plasterboards type DF manufactured by Norgips Sp. z o.o. and placed vertically, filled with mineral glass wool Aku – 100 mm thick board. Building Research Institute (Instytut Techniki Budowlanej).
- 1.9. Standard PN-EN 520+A1:2012 Gypsum plasterboards – Definitions, requirements and test methods.
- 1.10. Standard PN-EN 10143:2006 Continuously hot-dip coated steel sheet and strip. Tolerances on dimensions and shape.
- 1.11. Test Reports LP-677.1/03, LP-677.2/03, LP-677.3/03, LP-677.4/03, LP-677.5/03, LP-677.6/03 regarding fire resistance tests of high non-loadbearing walls with steel frameworks and lining made of gypsum plasterboards (6 tests).
- 1.12. Technical documentation provided by Norgips Sp. z o.o.

2. Technical description of walls

High single partition walls, double sided lined with gypsum plasterboards type DF manufactured by Norgips Sp. z o.o., either filled or not filled with insulation, are the object of fire resistance classification. Details of the construction of the walls covered by the classification are presented in items 2.1 ÷ 2.9.

2.1 Framework walls NORGIPS SD-2x12.5 DF CW 100+CW 100, SD-2x12.5 DFH2 CW 100+CW 100, SD-2x12.5 DFH2IR CW 100+CW 100, made of doubled profiles NORGIPS CW 100 placed every 60 cm, with the lining made of two layers of 12.5 mm thick boards NORGIPS types DF, DFH2, DFH2IR, either filled or not filled with mineral wool

The wall is built on the framework made of:

- profiles NORGIPS CW 100 and UW 100 which were made of 0.6 ± 0.06 mm thick cold bent galvanized steel in accordance with standard PN-EN 14195 [1.7], and

- profiles U 100/80, U 100/100, U 100/120, U 100/140, two angle elements 2L 100/120 or 2L 100/140 made of 1 ± 0.06 mm thick steel.

The vertical profiles placed around the perimeter – profiles CW 100 – are fixed to the side walls (side elements) while the bottom horizontal profiles placed around the perimeter – profiles UW 100 – are fixed to the floor by means of steel dowels of the minimum dimensions of $\varnothing 6 \times 40$ mm, placed at most every 80 cm (for details please see Figure 12).

The rules used for selecting the type of the top connection between the wall and the ceiling/roof (sliding connection, extended sliding connection) depending on the design deflection of the ceiling/roof during fire and the design vertical movement of the top of a pillar during fire are presented in item 2.10.

The following top perimeter profiles: profiles U 100/80, U 100/100, U 100/120 or U 100/140, are fixed to the ceiling/roof by means of:

- steel dowels of the minimum dimensions of $\varnothing 6 \times 40$ mm, placed at most every 80 cm (for details please see Figures 2b and 4c),
- steel dowels of the minimum dimensions of $\varnothing 6 \times 120$ mm, placed at most every 80 cm, through five layers of strips made of 12.5 mm thick gypsum plasterboards or through four layers of strips made of 15 mm thick gypsum plasterboards (for details please see Figures 4a and 4b).

The following top perimeter profiles: double angle elements 2L 100/120 or 2L 100/140, are fixed to the ceiling/roof by means of:

- steel dowels of the minimum dimensions of $\varnothing 6 \times 40$ mm, placed in two rows and at most every 80 cm (for details please see Figure 8c),
- steel dowels of the minimum dimensions of $\varnothing 6 \times 120$ mm, placed in two rows and at most every 80 cm, through five layers of strips made of 12.5 mm thick gypsum plasterboards or through four layers of strips made of 15 mm thick gypsum plasterboards (for details please see Figures 8a and 8b).

Sealing tape NORGIPS 100 is placed between the perimeter steel profiles and the ceiling/roof, floor and side walls.

Vertical posts are made of two profiles CW 100 which adjoin to each other at their webs. These profiles are connected with one another by means of screws with self-drilling endings NORGIPS $\varnothing 3.5 \times 9.5$ mm placed approximately every 50 cm in a staggered arrangement.

The posts are pushed in the inside of the horizontal perimeter profiles (top and bottom) every 60 cm or every 62.5 cm.

Profiles CW 100 can be connected with one another in such a way that their endings are connected (see Figure 15).

The walls are double sided covered with two layers of the following gypsum plasterboards meeting the requirements presented in standard PN-EN 520 [1.9]: NORGIPS S (fireproof) GKF type DF, NORGIPS S (fireproof and impregnated) GKFI type DFH2, or NORGIPS S Acoustic Super type DFH2IR. The aforementioned gypsum plasterboards are 12.5 mm thick and the declared minimum surface density of the plasterboards is as follows:

- NORGIPS (fireproof) GKF type DF – 10.1 kg/m^2 ,
- NORGIPS (fireproof and impregnated) GKFI type DFH2 – 10.1 kg/m^2 ,
- NORGIPS Acoustic Super type DFH2IR – 11.5 kg/m^2 .

The applied gypsum plasterboards are placed and fixed vertically. The vertical edges of the gypsum plasterboards are placed on the posts or on the vertical perimeter profiles of the framework.

The first layer of the boards is fixed to profiles UW 100 (the bottom perimeter profile) and profiles CW 100 (posts and vertical perimeter profiles) by means of screws NORGIPS Ø 3.5 x 25 mm placed at most every 75 cm. The second layer of the boards is fixed by means of screws NORGIPS Ø 3.5 x 35 mm placed at most every 25 cm. The boards are fixed in such a way that in the first layer of the lining of the wall, for each post, there are no vertical connections made from two sides of the wall.

The vertical connections from two sides of the walls in the first layers of the wall lining are shifted in relation to one another by 60 cm (62.5 cm). The horizontal connections in the first layer of the boards are shifted in relation to the horizontal connections between the adjacent boards of this layer by at least 40 cm.

The vertical connections in the second layer of the lining are shifted in relation to the vertical connections in the first layer of this lining by 60 cm (62.5 cm). The horizontal connections in the second layer of the boards are shifted in relation to the horizontal connections between the adjacent boards of this layer by at least 40 cm. The horizontal connections in the second layer of the lining are shifted in relation to the horizontal connections in the first layer of the lining by at least 40 cm.

Screw heads, the vertical and horizontal connections between the boards as well as perimeter sealing of each layer of the boards are covered with putty NORGIPS Start or NORGIPS Super Filler, while the vertical and horizontal connections in the second (external) layers of the boards are additionally reinforced with interfacing or mesh, reinforcing tape NORGIPS made of glass fibre.

The walls can be filled with mineral glass or rock wool (the maximum thickness of the wool used: 100 mm, the density of the wool used: 15 – 50 kg/m³). It is permitted to use no insulation made of mineral wool, i.e. to leave the inside of the wall empty and filled only with air.

Electric cables and wall boxes for electric installations can be installed in the wall, in accordance with Figure 16.

2.2 Framework walls NORGIPS SD-2x12.5 DF CW 100, SD-2x12.5 DFH2 CW 100, SD-2x12.5 DFH2IR CW 100, made of single profiles NORGIPS CW 100 placed every 30 cm, with the lining made of two layers of 12.5 mm thick boards NORGIPS types DF, DFH2, DFH2IR, either filled or not filled with mineral wool

The wall is built on the framework made of:

- profiles NORGIPS CW 100 and UW 100 which were made of 0.6 ± 0.06 mm thick cold bent galvanized steel in accordance with standard PN-EN 14195 [1.7], and
- profiles U 100/80, U 100/100, U 100/120, U 100/140, two angle elements 2L 100/120 or 2L 100/140 made of 1 ± 0.06 mm thick steel.

The vertical profiles placed around the perimeter – profiles CW 100 – are fixed to the side walls (side elements) while the bottom horizontal profiles placed around the perimeter – profiles UW 100 –

are fixed to the floor by means of steel dowels of the minimum dimensions of $\varnothing 6 \times 40$ mm, placed at most every 80 cm (for details please see Figure 11).

The rules used for selecting the type of the top connection between the wall and the ceiling/roof (sliding connection, extended sliding connection) depending on the design deflection of the ceiling/roof during fire and the design vertical movement of the top of a pillar during fire are presented in item 2.10.

The following top perimeter profiles: profiles U 100/80, U 100/100, U 100/120 or U 100/140, are fixed to the ceiling/roof by means of:

- steel dowels of the minimum dimensions of $\varnothing 6 \times 40$ mm, placed at most every 80 cm (for details please see Figures 2a and 3c),
- steel dowels of the minimum dimensions of $\varnothing 6 \times 120$ mm, placed at most every 80 cm, through five layers of strips made of 12.5 mm thick gypsum plasterboards or through four layers of strips made of 15 mm thick gypsum plasterboards (for details please see Figures 3a and 3b).

The following top perimeter profiles: double angle elements 2L 100/120 or 2L 100/140, are fixed to the ceiling/roof by means of:

- steel dowels of the minimum dimensions of $\varnothing 6 \times 40$ mm, placed in two rows and at most every 80 cm (for details please see Figure 7c),
- steel dowels of the minimum dimensions of $\varnothing 6 \times 120$ mm, placed in two rows and at most every 80 cm, through five layers of strips made of 12.5 mm thick gypsum plasterboards or through four layers of strips made of 15 mm thick gypsum plasterboards (for details please see Figures 7a and 7b).

Sealing tape NORGIPS 100 is placed between the perimeter steel profiles and the ceiling/roof, floor and side walls.

Vertical posts are made of single profiles CW 100. The posts are pushed in the inside of the horizontal perimeter profiles (top and bottom) every 30 cm or every 31.3 cm.

Profiles CW 100 can be connected with one another in such a way that their endings are connected (see Figure 15).

The walls are double sided covered with two layers of the following gypsum plasterboards meeting the requirements presented in standard PN-EN 520 [1.9]: NORGIPS S (fireproof) GKF type DF, NORGIPS S (fireproof and impregnated) GKFI type DFH2, or NORGIPS S Acoustic Super type DFH2IR. The aforementioned gypsum plasterboards are 12.5 mm thick and the declared minimum surface density of the plasterboards is as follows:

- NORGIPS (fireproof) GKF type DF – 10.1 kg/m²,
- NORGIPS (fireproof and impregnated) GKFI type DFH2 – 10.1 kg/m²,
- NORGIPS Acoustic Super type DFH2IR – 11.5 kg/m².

The applied gypsum plasterboards are placed and fixed vertically. The vertical edges of the gypsum plasterboards are placed on the posts or on the vertical perimeter profiles of the framework.

The first layer of the boards is fixed to profiles UW 100 (the bottom perimeter profile) and profiles CW 100 (posts and vertical perimeter profiles) by means of screws NORGIPS $\varnothing 3.5 \times 25$ mm placed

at most every 75 cm. The second layer of the boards is fixed by means of screws NORGIPS Ø 3.5 x 35 mm placed at most every 25 cm. The boards are fixed in such a way that in the first layer of the lining of the wall, for each post, there are no vertical connections made from two sides of the wall.

The vertical connections from two sides of the walls in the first layers of the wall lining are shifted in relation to one another by 60 cm (62.5 cm). The horizontal connections in the first layer of the boards are shifted in relation to the horizontal connections between the adjacent boards of this layer by at least 40 cm.

The vertical connections in the second layer of the lining are shifted in relation to the vertical connections in the first layer of this lining by 60 cm (62.5 cm). The horizontal connections in the second layer of the boards are shifted in relation to the horizontal connections between the adjacent boards of this layer by at least 40 cm. The horizontal connections in the second layer of the lining are shifted in relation to the horizontal connections in the first layer of the lining by at least 40 cm.

Screw heads, the vertical and horizontal connections between the boards as well as perimeter sealing of each layer of the boards are covered with putty NORGIPS Start or NORGIPS Super Filler, while the vertical and horizontal connections in the second (external) layers of the boards are additionally reinforced with interfacing or mesh, reinforcing tape NORGIPS made of glass fibre.

The walls can be filled with mineral glass or rock wool (the maximum thickness of the wool used: 100 mm, the density of the wool used: 15 – 50 kg/m³). It is permitted to use no insulation made of mineral wool, i.e. to leave the inside of the wall empty and filled only with air.

Electric cables and wall boxes for electric installations can be installed in the wall, in accordance with Figure 16.

2.3 Framework walls NORGIPS SD-2x12.5 DF CW 100+CW 100, SD-2x12.5 DFH2 CW 100+CW 100, SD-2x12.5 DFH2IR CW 100+CW 100, made of doubled profiles NORGIPS CW 100 placed every 40 cm, with the lining made of two layers of 12.5 mm thick boards NORGIPS types DF, DFH2, DFH2IR, either filled or not filled with mineral wool

The wall is built on the framework made of:

- profiles NORGIPS CW 100 and UW 100 which were made of 0.6 ± 0.06 mm thick cold bent galvanized steel in accordance with standard PN-EN 14195 [1.7], and
- profiles U 100/80, U 100/100, U 100/120, U 100/140, two angle elements 2L 100/120 or 2L 100/140 made of 1 ± 0.06 mm thick steel.

The vertical profiles placed around the perimeter – profiles CW 100 – are fixed to the side walls (side elements) while the bottom horizontal profiles placed around the perimeter – profiles UW 100 – are fixed to the floor by means of steel dowels of the minimum dimensions of Ø 6 x 40 mm, placed at most every 80 cm (for details please see Figure 12).

The rules used for selecting the type of the top connection between the wall and the ceiling/roof (sliding connection, extended sliding connection) depending on the design deflection of the ceiling/roof during fire and the design vertical movement of the top of a pillar during fire are presented in item 2.10.

The following top perimeter profiles: profiles U 100/80, U 100/100, U 100/120 or U 100/140, are fixed to the ceiling/roof by means of:

- steel dowels of the minimum dimensions of $\varnothing 6 \times 40$ mm, placed at most every 80 cm (for details please see Figures 2b and 4c),
- steel dowels of the minimum dimensions of $\varnothing 6 \times 120$ mm, placed at most every 80 cm, through five layers of strips made of 12.5 mm thick gypsum plasterboards or through four layers of strips made of 15 mm thick gypsum plasterboards (for details please see Figures 4a and 4b).

The following top perimeter profiles: double angle elements 2L 100/120 or 2L 100/140, are fixed to the ceiling/roof by means of:

- steel dowels of the minimum dimensions of $\varnothing 6 \times 40$ mm, placed in two rows and at most every 80 cm (for details please see Figure 8c),
- steel dowels of the minimum dimensions of $\varnothing 6 \times 120$ mm, placed in two rows and at most every 80 cm, through five layers of strips made of 12.5 mm thick gypsum plasterboards or through four layers of strips made of 15 mm thick gypsum plasterboards (for details please see Figures 8a and 8b).

Sealing tape NORGIPS 100 is placed between the perimeter steel profiles and the ceiling/roof, floor and side walls.

Vertical posts are made of two profiles CW 100 which adjoin to each other at their webs. These profiles are connected with one another by means of screws with self-drilling endings NORGIPS $\varnothing 3.5 \times 9.5$ mm placed approximately every 50 cm in a staggered arrangement.

The posts are pushed in the inside of the horizontal perimeter profiles (top and bottom) every 40 cm or every 41.7 cm.

Profiles CW 100 can be connected with one another in such a way that their endings are connected (see Figure 15).

The walls are double sided covered with two layers of the following gypsum plasterboards meeting the requirements presented in standard PN-EN 520 [1.9]: NORGIPS S (fireproof) GKF type DF, NORGIPS S (fireproof and impregnated) GKFI type DFH2, or NORGIPS S Acoustic Super type DFH2IR. The aforementioned gypsum plasterboards are 12.5 mm thick and the declared minimum surface density of the plasterboards is as follows:

- NORGIPS (fireproof) GKF type DF – 10.1 kg/m²,
- NORGIPS (fireproof and impregnated) GKFI type DFH2 – 10.1 kg/m²,
- NORGIPS Acoustic Super type DFH2IR – 11.5 kg/m².

The applied gypsum plasterboards are placed and fixed vertically. The vertical edges of the gypsum plasterboards are placed on the posts or on the vertical perimeter profiles of the framework.

The first layer of the boards is fixed to profiles UW 100 (the bottom perimeter profile) and profiles CW 100 (posts and vertical perimeter profiles) by means of screws NORGIPS $\varnothing 3.5 \times 25$ mm placed at most every 75 cm. The second layer of the boards is fixed by means of screws NORGIPS $\varnothing 3.5 \times 35$ mm placed at most every 25 cm. The boards are fixed in such a way that in the first layer of the lining of the wall, for each post, there are no vertical connections made from two sides of the wall.

The vertical connections from two sides of the walls in the first layers of the wall lining are shifted in relation to one another by 40 cm (41.7 cm). The horizontal connections in the first layer of the boards are shifted in relation to the horizontal connections between the adjacent boards of this layer by at least 40 cm.

The vertical connections in the second layer of the lining are shifted in relation to the vertical connections in the first layer of this lining by 40 cm (41.7 cm). The horizontal connections in the second layer of the boards are shifted in relation to the horizontal connections between the adjacent boards of this layer by at least 40 cm. The horizontal connections in the second layer of the lining are shifted in relation to the horizontal connections in the first layer of the lining by at least 40 cm.

Screw heads, the vertical and horizontal connections between the boards as well as perimeter sealing of each layer of the boards are covered with putty NORGIPS Start or NORGIPS Super Filler, while the vertical and horizontal connections in the second (external) layers of the boards are additionally reinforced with interfacing or mesh, reinforcing tape NORGIPS made of glass fibre.

The walls can be filled with mineral glass or rock wool (the maximum thickness of the wool used: 100 mm, the density of the wool used: 15 – 50 kg/m³). It is permitted to use no insulation made of mineral wool, i.e. to leave the inside of the wall empty and filled only with air.

Electric cables or wall boxes for electric installations can be installed in the wall, in accordance with Figure 16.

2.4 Framework walls NORGIPS SD-3x12.5 DF CW 100+CW 100, SD-3x12.5 DFH2 CW 100+CW 100, SD-3x12.5 DFH2IR CW 100+CW 100, made of doubled profiles NORGIPS CW 100 placed every 60 cm, with the lining made of three layers of 12.5 mm thick boards NORGIPS types DF, DFH2, DFH2IR, either filled or not filled with mineral wool

The wall is built on the framework made of:

- profiles NORGIPS CW 100 and UW 100 which were made of 0.6 ± 0.06 mm thick cold bent galvanized steel in accordance with standard PN-EN 14195 [1.7], and
- profiles U 100/80, U 100/100, U 100/120, U 100/140, two angle elements 2L 100/120 or 2L 100/140 made of 1 ± 0.06 mm thick steel.

The vertical profiles placed around the perimeter – profiles CW 100 – are fixed to the side walls (side elements) while the bottom horizontal profiles placed around the perimeter – profiles UW 100 – are fixed to the floor by means of steel dowels of the minimum dimensions of $\varnothing 6 \times 40$ mm, placed at most every 80 cm (for details please see Figure 14).

The rules used for selecting the type of the top connection between the wall and the ceiling/roof (sliding connection, extended sliding connection) depending on the design deflection of the ceiling/roof during fire and the design vertical movement of the top of a pillar during fire are presented in item 2.10.

The following top perimeter profiles: profiles U 100/80, U 100/100, U 100/120 or U 100/140, are fixed to the ceiling/roof by means of:

- steel dowels of the minimum dimensions of $\varnothing 6 \times 40$ mm, placed at most every 80 cm (for details please see Figures 2d and 6c),
- steel dowels of the minimum dimensions of $\varnothing 6 \times 120$ mm, placed at most every 80 cm, through five layers of strips made of 12.5 mm thick gypsum plasterboards or through four layers of strips made of 15 mm thick gypsum plasterboards (for details please see Figures 6a and 6b).

The following top perimeter profiles: double angle elements 2L 100/120 or 2L 100/140, are fixed to the ceiling/roof by means of:

- steel dowels of the minimum dimensions of $\varnothing 6 \times 40$ mm, placed in two rows and at most every 80 cm (for details please see Figure 10c),
- steel dowels of the minimum dimensions of $\varnothing 6 \times 120$ mm, placed in two rows and at most every 80 cm, through five layers of strips made of 12.5 mm thick gypsum plasterboards or through four layers of strips made of 15 mm thick gypsum plasterboards (for details please see Figures 10a and 10b).

Sealing tape NORGIPS 100 is placed between the perimeter steel profiles and the ceiling/roof, floor and side walls.

Vertical posts are made of two profiles CW 100 which adjoin to each other at their webs. These profiles are connected with one another by means of screws with self-drilling endings NORGIPS $\varnothing 3.5 \times 9.5$ mm placed approximately every 50 cm in a staggered arrangement.

The posts are pushed in the inside of the horizontal perimeter profiles (top and bottom) every 60 cm or every 62.5 cm.

Profiles CW 100 can be connected with one another in such a way that their endings are connected (see Figure 15).

The walls are double sided covered with two layers of the following gypsum plasterboards meeting the requirements presented in standard PN-EN 520 [1.9]: NORGIPS S (fireproof) GKF type DF, NORGIPS S (fireproof and impregnated) GKFI type DFH2, or NORGIPS S Acoustic Super type DFH2IR. The aforementioned gypsum plasterboards are 12.5 mm thick and the declared minimum surface density of the plasterboards is as follows:

- NORGIPS (fireproof) GKF type DF – 10.1 kg/m²,
- NORGIPS (fireproof and impregnated) GKFI type DFH2 – 10.1 kg/m²,
- NORGIPS Acoustic Super type DFH2IR – 11.5 kg/m².

The applied gypsum plasterboards are placed and fixed vertically. The vertical edges of the gypsum plasterboards are placed on the posts or on the vertical perimeter profiles of the framework.

The first layer of the boards is fixed to profiles UW 100 (the bottom perimeter profile) and profiles CW 100 (posts and vertical perimeter profiles) by means of screws NORGIPS $\varnothing 3.5 \times 25$ mm placed at most every 75 cm. The second layer of the boards is fixed by means of screws NORGIPS $\varnothing 3.5 \times 35$ mm placed at most every 50 cm. The third layer of the boards is fixed by means of screws NORGIPS $\varnothing 3.5 \times 55$ mm placed at most every 25 cm. The boards are fixed in such a way that in the first layer of the lining of the wall, for each post, there are no vertical connections made from two sides of the wall.

The vertical connections from two sides of the walls in the first layers of the wall lining are shifted in relation to one another by 60 cm (62.5 cm). The horizontal connections in the first layer of the boards are shifted in relation to the horizontal connections between the adjacent boards of this layer by at least 40 cm.

The vertical connections in the second layer of the lining are shifted in relation to the vertical connections in the first layer of this lining by 60 cm (62.5 cm). The horizontal connections in the second layer of the boards are shifted in relation to the horizontal connections between the adjacent boards of this layer by at least 40 cm. The horizontal connections in the second layer of the lining are shifted in relation to the horizontal connections in the first layer of the lining by at least 40 cm.

The vertical connections in the third layer of the lining are shifted in relation to the vertical connections in the second layer of this lining by 60 cm (62.5 cm). The horizontal connections in the third layer of the boards are shifted in relation to the horizontal connections between the adjacent boards of this layer by at least 40 cm. The horizontal connections in the third layer of the lining are shifted in relation to the horizontal connections in the second layer of the lining by at least 40 cm.

Screw heads, the vertical and horizontal connections between the boards as well as perimeter sealing of each layer of the boards are covered with putty NORGIPS Start or NORGIPS Super Filler, while the vertical and horizontal connections in the third (external) layers of the boards are additionally reinforced with interfacing or mesh, reinforcing tape NORGIPS made of glass fibre.

The walls can be filled with mineral glass or rock wool (the maximum thickness of the wool used: 100 mm, the density of the wool used: 15 – 50 kg/m³). It is permitted to use no insulation made of mineral wool, i.e. to leave the inside of the wall empty and filled only with air.

Electric cables and wall boxes for electric installations can be installed in the wall, in accordance with Figure 16.

2.5 Framework walls NORGIPS SD-3x12.5 DF CW 100, SD-3x12.5 DFH2 CW 100, SD-3x12.5 DFH2IR CW 100, made of single profiles NORGIPS CW 100 placed every 30 cm, with the lining made of three layers of 12.5 mm thick boards NORGIPS types DF, DFH2, DFH2IR, either filled or not filled with mineral wool

The wall is built on the framework made of:

- profiles NORGIPS CW 100 and UW 100 which were made of 0.6 ± 0.06 mm thick cold bent galvanized steel in accordance with standard PN-EN 14195 [1.7], and
- profiles U 100/80, U 100/100, U 100/120, U 100/140, two angle elements 2L 100/120 or 2L 100/140 made of 1 ± 0.06 mm thick steel.

The vertical profiles placed around the perimeter – profiles CW 100 – are fixed to the side walls (side elements) while the bottom horizontal profiles placed around the perimeter – profiles UW 100 – are fixed to the floor by means of steel dowels of the minimum dimensions of $\varnothing 6 \times 40$ mm, placed at most every 80 cm (for details please see Figure 13).

The rules used for selecting the type of the top connection between the wall and the ceiling/roof (sliding connection, extended sliding connection) depending on the design deflection of the

ceiling/roof during fire and the design vertical movement of the top of a pillar during fire are presented in item 2.10.

The following top perimeter profiles: profiles U 100/80, U 100/100, U 100/120 or U 100/140, are fixed to the ceiling/roof by means of:

- steel dowels of the minimum dimensions of $\varnothing 6 \times 40$ mm, placed at most every 80 cm (for details please see Figures 2c and 5c),
- steel dowels of the minimum dimensions of $\varnothing 6 \times 120$ mm, placed at most every 80 cm, through five layers of strips made of 12.5 mm thick gypsum plasterboards or through four layers of strips made of 15 mm thick gypsum plasterboards (for details please see Figures 5a and 5b).

The following top perimeter profiles: double angle elements 2L 100/120 or 2L 100/140, are fixed to the ceiling/roof by means of:

- steel dowels of the minimum dimensions of $\varnothing 6 \times 40$ mm, placed in two rows and at most every 80 cm (for details please see Figure 9c),
- steel dowels of the minimum dimensions of $\varnothing 6 \times 120$ mm, placed in two rows and at most every 80 cm, through five layers of strips made of 12.5 mm thick gypsum plasterboards or through four layers of strips made of 15 mm thick gypsum plasterboards (for details please see Figures 9a and 9b).

Sealing tape NORGIPS 100 is placed between the perimeter steel profiles and the ceiling/roof, floor and side walls.

Vertical posts are made of single profiles CW 100. The posts are pushed in the inside of the horizontal perimeter profiles (top and bottom) every 30 cm or every 31.3 cm.

Profiles CW 100 can be connected with one another in the way presented in Figure 15.

The walls are double sided covered with three layers of the following gypsum plasterboards meeting the requirements presented in standard PN-EN 520 [1.9]: NORGIPS S (fireproof) GKF type DF, NORGIPS S (fireproof and impregnated) GKFI type DFH2, or NORGIPS S Acoustic Super type DFH2IR. The aforementioned gypsum plasterboards are 12.5 mm thick and the declared minimum surface density of the plasterboards is as follows:

- NORGIPS (fireproof) GKF type DF – 10.1 kg/m²,
- NORGIPS (fireproof and impregnated) GKFI type DFH2 – 10.1 kg/m²,
- NORGIPS Acoustic Super type DFH2IR – 11.5 kg/m².

The applied gypsum plasterboards are placed and fixed vertically. The vertical edges of the gypsum plasterboards are placed on the posts or on the vertical perimeter profiles of the framework.

The first layer of the boards is fixed to profiles UW 100 (the bottom perimeter profile) and profiles CW 100 (posts and vertical perimeter profiles) by means of screws NORGIPS $\varnothing 3.5 \times 25$ mm placed at most every 75 cm. The second layer of the boards is fixed by means of screws NORGIPS $\varnothing 3.5 \times 35$ mm placed at most every 50 cm. The third layer of the boards is fixed by means of screws NORGIPS $\varnothing 3.5 \times 55$ mm placed at most every 25 cm. The boards are fixed in such a way that in the first layer of the lining of the wall, for each post, there are no vertical connections made from two sides of the wall.

The vertical connections from two sides of the walls in the first layers of the wall lining are shifted in relation to one another by 60 cm (62.5 cm). The horizontal connections in the first layer of the boards are shifted in relation to the horizontal connections between the adjacent boards of this layer by at least 40 cm.

The vertical connections in the second layer of the lining are shifted in relation to the vertical connections in the first layer of this lining by 60 cm (62.5 cm). The horizontal connections in the second layer of the boards are shifted in relation to the horizontal connections between the adjacent boards of this layer by at least 40 cm. The horizontal connections in the second layer of the lining are shifted in relation to the horizontal connections in the first layer of the lining by at least 40 cm.

The vertical connections in the third layer of the lining are shifted in relation to the vertical connections in the second layer of this lining by 60 cm (62.5 cm). The horizontal connections in the third layer of the boards are shifted in relation to the horizontal connections between the adjacent boards of this layer by at least 40 cm. The horizontal connections in the third layer of the lining are shifted in relation to the horizontal connections in the second layer of the lining by at least 40 cm.

Screw heads, the vertical and horizontal connections between the boards as well as perimeter sealing of each layer of the boards are covered with putty NORGIPS Start or NORGIPS Super Filler, while the vertical and horizontal connections in the third (external) layers of the boards are additionally reinforced with interfacing or mesh, reinforcing tape NORGIPS made of glass fibre.

The walls can be filled with mineral glass or rock wool (the maximum thickness of the wool used: 100 mm, the density of the wool used: 15 – 50 kg/m³). It is permitted to use no insulation made of mineral wool, i.e. to leave the inside of the wall empty and filled only with air.

Electric cables and wall boxes for electric installations can be installed in the wall, in accordance with Figure 16.

2.6 Framework walls NORGIPS SD-3x12.5 DF CW 100+CW 100, SD-3x12.5 DFH2 CW 100+CW 100, SD-3x12.5 DFH2IR CW 100+CW 100, made of doubled profiles NORGIPS CW 100 placed every 40 cm, with the lining made of three layers of 12.5 mm thick boards NORGIPS types DF, DFH2, DFH2IR, either filled or not filled with mineral wool

The wall is built on the framework made of:

- profiles NORGIPS CW 100 and UW 100 which were made of 0.6 ± 0.06 mm thick cold bent galvanized steel in accordance with standard PN-EN 14195 [1.7], and
- profiles U 100/80, U 100/100, U 100/120, U 100/140, two angle elements 2L 100/120 or 2L 100/140 made of 1 ± 0.06 mm thick steel.

The vertical profiles placed around the perimeter – profiles CW 100 – are fixed to the side walls (side elements) while the bottom horizontal profiles placed around the perimeter – profiles UW 100 – are fixed to the floor by means of steel dowels of the minimum dimensions of $\varnothing 6 \times 40$ mm, placed at most every 80 cm (for details please see Figure 14).

The rules used for selecting the type of the top connection between the wall and the ceiling/roof (sliding connection, extended sliding connection) depending on the design deflection of the

ceiling/roof during fire and the design vertical movement of the top of a pillar during fire are presented in item 2.10.

The following top perimeter profiles: profiles U 100/80, U 100/100, U 100/120 or U 100/140, are fixed to the ceiling/roof by means of:

- steel dowels of the minimum dimensions of $\varnothing 6 \times 40$ mm, placed at most every 80 cm (for details please see Figures 2d and 6c),
- steel dowels of the minimum dimensions of $\varnothing 6 \times 120$ mm, placed at most every 80 cm, through five layers of strips made of 12.5 mm thick gypsum plasterboards or through four layers of strips made of 15 mm thick gypsum plasterboards (for details please see Figures 6a and 6b).

The following top perimeter profiles: double angle elements 2L 100/120 or 2L 100/140, are fixed to the ceiling/roof by means of:

- steel dowels of the minimum dimensions of $\varnothing 6 \times 40$ mm, placed in two rows and at most every 80 cm (for details please see Figure 10c),
- steel dowels of the minimum dimensions of $\varnothing 6 \times 120$ mm, placed in two rows and at most every 80 cm, through five layers of strips made of 12.5 mm thick gypsum plasterboards or through four layers of strips made of 15 mm thick gypsum plasterboards (for details please see Figures 10a and 10b).

Sealing tape NORGIPS 100 is placed between the perimeter steel profiles and the ceiling/roof, floor and side walls.

Vertical posts are made of two profiles CW 100 which adjoin to each other at their webs. These profiles are connected with one another by means of screws with self-drilling endings NORGIPS $\varnothing 3.5 \times 9.5$ mm placed approximately every 50 cm in a staggered arrangement.

The posts are pushed in the inside of the horizontal perimeter profiles (top and bottom) every 40 cm or every 41.7 cm.

Profiles CW 100 can be connected with one another in such a way that their endings are connected (see Figure 15).

The walls are double sided covered with three layers of the following gypsum plasterboards meeting the requirements presented in standard PN-EN 520 [1.9]: NORGIPS S (fireproof) GKF type DF, NORGIPS S (fireproof and impregnated) GKFI type DFH2, or NORGIPS S Acoustic Super type DFH2IR. The aforementioned gypsum plasterboards are 12.5 mm thick and the declared minimum surface density of the plasterboards is as follows:

- NORGIPS (fireproof) GKF type DF – 10.1 kg/m²,
- NORGIPS (fireproof and impregnated) GKFI type DFH2 – 10.1 kg/m²,
- NORGIPS Acoustic Super type DFH2IR – 11.5 kg/m².

The applied gypsum plasterboards are placed and fixed vertically. The vertical edges of the gypsum plasterboards are placed on the posts or on the vertical perimeter profiles of the framework.

The first layer of the boards is fixed to profiles UW 100 (the bottom perimeter profile) and profiles CW 100 (posts and vertical perimeter profiles) by means of screws NORGIPS $\varnothing 3.5 \times 25$ mm placed at most every 75 cm. The second layer of the boards is fixed by means of screws NORGIPS $\varnothing 3.5 \times 35$ mm placed at most every 50 cm. The third layer of the boards is fixed by means of screws

NORGIPS Ø 3.5 x 55 mm placed at most every 25 cm. The boards are fixed in such a way that in the first layer of the lining of the wall, for each post, there are no vertical connections made from two sides of the wall.

The vertical connections from two sides of the walls in the first layers of the wall lining are shifted in relation to one another by 40 cm (41.7 cm). The horizontal connections in the first layer of the boards are shifted in relation to the horizontal connections between the adjacent boards of this layer by at least 40 cm.

The vertical connections in the second layer of the lining are shifted in relation to the vertical connections in the first layer of this lining by 40 cm (41.7 cm). The horizontal connections in the second layer of the boards are shifted in relation to the horizontal connections between the adjacent boards of this layer by at least 40 cm. The horizontal connections in the second layer of the lining are shifted in relation to the horizontal connections in the first layer of the lining by at least 40 cm.

The vertical connections in the third layer of the lining are shifted in relation to the vertical connections in the second layer of this lining by 40 cm (41.7 cm). The horizontal connections in the third layer of the boards are shifted in relation to the horizontal connections between the adjacent boards of this layer by at least 40 cm. The horizontal connections in the third layer of the lining are shifted in relation to the horizontal connections in the second layer of the lining by at least 40 cm.

Screw heads, the vertical and horizontal connections between the boards as well as perimeter sealing of each layer of the boards are covered with putty NORGIPS Start or NORGIPS Super Filler, while the vertical and horizontal connections in the third (external) layers of the boards are additionally reinforced with interfacing or mesh, reinforcing tape NORGIPS made of glass fibre.

The walls can be filled with mineral glass or rock wool (the maximum thickness of the wool used: 100 mm, the density of the wool used: 15 – 50 kg/m³). It is permitted to use no insulation made of mineral wool, i.e. to leave the inside of the wall empty and filled only with air.

Electric cables and wall boxes for electric installations can be installed in the wall, in accordance with Figure 16.

2.7 Framework walls NORGIPS SD-3x15 DF CW 100+CW 100, SD-3x15 DFH2 CW 100+CW 100, SD-3x15 DFH2IR CW 100+CW 100, made of doubled profiles NORGIPS CW 100 placed every 60 cm, with the lining made of three layers of 15 mm thick boards NORGIPS types DF, DFH2, DFH2IR, either filled or not filled with mineral wool

The wall is built on the framework made of:

- profiles NORGIPS CW 100 and UW 100 which were made of 0.6 ± 0.06 mm thick cold bent galvanized steel in accordance with standard PN-EN 14195 [1.7], and
- profiles U 100/80, U 100/100, U 100/120, U 100/140, two angle elements 2L 100/120 or 2L 100/140 made of 1 ± 0.06 mm thick steel.

The vertical profiles placed around the perimeter – profiles CW 100 – are fixed to the side walls (side elements) while the bottom horizontal profiles placed around the perimeter – profiles UW 100 –

are fixed to the floor by means of steel dowels of the minimum dimensions of $\varnothing 6 \times 40$ mm, placed at most every 80 cm (for details please see Figure 14).

The rules used for selecting the type of the top connection between the wall and the ceiling/roof (sliding connection, extended sliding connection) depending on the design deflection of the ceiling/roof during fire and the design vertical movement of the top of a pillar during fire are presented in item 2.10.

The following top perimeter profiles: profiles U 100/80, U 100/100, U 100/120 or U 100/140, are fixed to the ceiling/roof by means of:

- steel dowels of the minimum dimensions of $\varnothing 6 \times 40$ mm, placed at most every 80 cm (for details please see Figures 2d and 6c),
- steel dowels of the minimum dimensions of $\varnothing 6 \times 120$ mm, placed at most every 80 cm, through five layers of strips made of 12.5 mm thick gypsum plasterboards or through four layers of strips made of 15 mm thick gypsum plasterboards (for details please see Figures 6a and 6b).

The following top perimeter profiles: double angle elements 2L 100/120 or 2L 100/140, are fixed to the ceiling/roof by means of:

- steel dowels of the minimum dimensions of $\varnothing 6 \times 40$ mm, placed in two rows and at most every 80 cm (for details please see Figure 10c),
- steel dowels of the minimum dimensions of $\varnothing 6 \times 120$ mm, placed in two rows and at most every 80 cm, through five layers of strips made of 12.5 mm thick gypsum plasterboards or through four layers of strips made of 15 mm thick gypsum plasterboards (for details please see Figures 10a and 10b).

Sealing tape NORGIPS 100 is placed between the perimeter steel profiles and the ceiling/roof, floor and side walls.

Vertical posts are made of two profiles CW 100 which adjoin to each other at their webs. These profiles are connected with one another by means of screws with self-drilling endings NORGIPS $\varnothing 3.5 \times 9.5$ mm placed approximately every 50 cm in a staggered arrangement.

The posts are pushed in the inside of the horizontal perimeter profiles (top and bottom) every 60 cm or every 62.5 cm.

Profiles CW 100 can be connected with one another in such a way that their endings are connected (see Figure 15).

The walls are double sided covered with three layers of the following gypsum plasterboards meeting the requirements presented in standard PN-EN 520 [1.9]: NORGIPS S (fireproof) GKF type DF, NORGIPS S (fireproof and impregnated) GKFI type DFH2, or NORGIPS S Acoustic Super type DFH2IR. The aforementioned gypsum plasterboards are 15 mm thick and the declared minimum surface density of the plasterboards is as follows:

- NORGIPS (fireproof) GKF type DF – 12.1 kg/m²,
- NORGIPS (fireproof and impregnated) GKFI type DFH2 – 12.1 kg/m²,
- NORGIPS Acoustic Super type DFH2IR – 13.5 kg/m².

The applied gypsum plasterboards are placed and fixed vertically. The vertical edges of the gypsum plasterboards are placed on the posts or on the vertical perimeter profiles of the framework.

The first layer of the boards is fixed to profiles UW 100 (the bottom perimeter profile) and profiles CW 100 (posts and vertical perimeter profiles) by means of screws NORGIPS Ø 3.5 x 25 mm placed at most every 75 cm. The second layer of the boards is fixed by means of screws NORGIPS Ø 3.5 x 35 mm placed at most every 50 cm. The third layer of the boards is fixed by means of screws NORGIPS Ø 3.5 x 55 mm placed at most every 25 cm. The boards are fixed in such a way that in the first layer of the lining of the wall, for each post, there are no vertical connections made from two sides of the wall.

The vertical connections from two sides of the walls in the first layers of the wall lining are shifted in relation to one another by 60 cm (62.5 cm). The horizontal connections in the first layer of the boards are shifted in relation to the horizontal connections between the adjacent boards of this layer by at least 40 cm.

The vertical connections in the second layer of the lining are shifted in relation to the vertical connections in the first layer of this lining by 60 cm (62.5 cm). The horizontal connections in the second layer of the boards are shifted in relation to the horizontal connections between the adjacent boards of this layer by at least 40 cm. The horizontal connections in the second layer of the lining are shifted in relation to the horizontal connections in the first layer of the lining by at least 40 cm.

The vertical connections in the third layer of the lining are shifted in relation to the vertical connections in the second layer of this lining by 60 cm (62.5 cm). The horizontal connections in the third layer of the boards are shifted in relation to the horizontal connections between the adjacent boards of this layer by at least 40 cm. The horizontal connections in the third layer of the lining are shifted in relation to the horizontal connections in the second layer of the lining by at least 40 cm.

Screw heads, the vertical and horizontal connections between the boards as well as perimeter sealing of each layer of the boards are covered with putty NORGIPS Start or NORGIPS Super Filler, while the vertical and horizontal connections in the third (external) layers of the boards are additionally reinforced with interfacing or mesh, reinforcing tape NORGIPS made of glass fibre.

The walls can be filled with mineral glass or rock wool (the maximum thickness of the wool used: 100 mm, the density of the wool used: 15 – 50 kg/m³). It is permitted to use no insulation made of mineral wool, i.e. to leave the inside of the wall empty and filled only with air.

Electric cables and wall boxes for electric installations can be installed in the wall, in accordance with Figure 16.

2.8 Framework walls NORGIPS SD-3x15 DF CW 100, SD-3x15 DFH2 CW 100, SD-3x15 DFH2IR CW 100, made of single profiles NORGIPS CW 100 placed every 30 cm, with the lining made of three layers of 15 mm thick boards NORGIPS types DF, DFH2, DFH2IR, either filled or not filled with mineral wool

The wall is built on the framework made of:

- profiles NORGIPS CW 100 and UW 100 which were made of 0.6 ± 0.06 mm thick cold bent galvanized steel in accordance with standard PN-EN 14195 [1.7], and
- profiles U 100/80, U 100/100, U 100/120, U 100/140, two angle elements 2L 100/120 or 2L 100/140 made of 1 ± 0.06 mm thick steel.

The vertical profiles placed around the perimeter – profiles CW 100 – are fixed to the side walls (side elements) while the bottom horizontal profiles placed around the perimeter – profiles UW 100 – are fixed to the floor by means of steel dowels of the minimum dimensions of $\varnothing 6 \times 40$ mm, placed at most every 80 cm (for details please see Figure 13).

The rules used for selecting the type of the top connection between the wall and the ceiling/roof (sliding connection, extended sliding connection) depending on the design deflection of the ceiling/roof during fire and the design vertical movement of the top of a pillar during fire are presented in item 2.10.

The following top perimeter profiles: profiles U 100/80, U 100/100, U 100/120 or U 100/140, are fixed to the ceiling/roof by means of:

- steel dowels of the minimum dimensions of $\varnothing 6 \times 40$ mm, placed at most every 80 cm (for details please see Figures 2c and 5c),
- steel dowels of the minimum dimensions of $\varnothing 6 \times 120$ mm, placed at most every 80 cm, through five layers of strips made of 12.5 mm thick gypsum plasterboards or through four layers of strips made of 15 mm thick gypsum plasterboards (for details please see Figures 5a and 5b).

The following top perimeter profiles: double angle elements 2L 100/120 or 2L 100/140, are fixed to the ceiling/roof by means of:

- steel dowels of the minimum dimensions of $\varnothing 6 \times 40$ mm, placed in two rows and at most every 80 cm (for details please see Figure 9c),
- steel dowels of the minimum dimensions of $\varnothing 6 \times 120$ mm, placed in two rows and at most every 80 cm, through five layers of strips made of 12.5 mm thick gypsum plasterboards or through four layers of strips made of 15 mm thick gypsum plasterboards (for details please see Figures 9a and 9b).

Sealing tape NORGIPS 100 is placed between the perimeter steel profiles and the ceiling/roof, floor and side walls.

Vertical posts are made of single profiles CW 100.

The posts are pushed in the inside of the horizontal perimeter profiles (top and bottom) every 30 cm or every 31.3 cm.

Profiles CW 100 can be connected with one another in such a way that their endings are connected (see Figure 15).

The walls are double sided covered with three layers of the following gypsum plasterboards meeting the requirements presented in standard PN-EN 520 [1.9]: NORGIPS S (fireproof) GKF type DF, NORGIPS S (fireproof and impregnated) GKFI type DFH2, or NORGIPS S Acoustic Super type DFH2IR. The aforementioned gypsum plasterboards are 15 mm thick and the declared minimum surface density of the plasterboards is as follows:

- NORGIPS (fireproof) GKF type DF – 12.1 kg/m²,
- NORGIPS (fireproof and impregnated) GKFI type DFH2 – 12.1 kg/m²,
- NORGIPS Acoustic Super type DFH2IR – 13.5 kg/m².

The applied gypsum plasterboards are placed and fixed vertically. The vertical edges of the gypsum plasterboards are placed on the posts or on the vertical perimeter profiles of the framework.

The first layer of the boards is fixed to profiles UW 100 (the bottom perimeter profile) and profiles CW 100 (posts and vertical perimeter profiles) by means of screws NORGIPS Ø 3.5 x 25 mm placed at most every 75 cm. The second layer of the boards is fixed by means of screws NORGIPS Ø 3.5 x 35 mm placed at most every 50 cm. The third layer of the boards is fixed by means of screws NORGIPS Ø 3.5 x 55 mm placed at most every 25 cm. The boards are fixed in such a way that in the first layer of the lining of the wall, for each post, there are no vertical connections made from two sides of the wall.

The vertical connections from two sides of the walls in the first layers of the wall lining are shifted in relation to one another by 60 cm (62.5 cm). The horizontal connections in the first layer of the boards are shifted in relation to the horizontal connections between the adjacent boards of this layer by at least 40 cm.

The vertical connections in the second layer of the lining are shifted in relation to the vertical connections in the first layer of this lining by 60 cm (62.5 cm). The horizontal connections in the second layer of the boards are shifted in relation to the horizontal connections between the adjacent boards of this layer by at least 40 cm. The horizontal connections in the second layer of the lining are shifted in relation to the horizontal connections in the first layer of the lining by at least 40 cm.

The vertical connections in the third layer of the lining are shifted in relation to the vertical connections in the second layer of this lining by 60 cm (62.5 cm). The horizontal connections in the third layer of the boards are shifted in relation to the horizontal connections between the adjacent boards of this layer by at least 40 cm. The horizontal connections in the third layer of the lining are shifted in relation to the horizontal connections in the second layer of the lining by at least 40 cm.

Screw heads, the vertical and horizontal connections between the boards as well as perimeter sealing of each layer of the boards are covered with putty NORGIPS Start or NORGIPS Super Filler, while the vertical and horizontal connections in the third (external) layers of the boards are additionally reinforced with interfacing or mesh, reinforcing tape NORGIPS made of glass fibre.

The walls can be filled with mineral glass or rock wool (the maximum thickness of the wool used: 100 mm, the density of the wool used: 15 – 50 kg/m³). It is permitted to use no insulation made of mineral wool, i.e. to leave the inside of the wall empty and filled only with air.

Electric cables and wall boxes for electric installations can be installed in the wall, in accordance with Figure 16.

2.9 Framework walls NORGIPS SD-3x15 DF CW 100+CW 100, SD-3x15 DFH2 CW 100+CW 100, SD-3x15 DFH2IR CW 100+CW 100, made of doubled profiles NORGIPS CW 100 placed every 40 cm, with the lining made of three layers of 15 mm thick boards NORGIPS types DF, DFH2, DFH2IR, either filled or not filled with mineral wool

The wall is built on the framework made of:

- profiles NORGIPS CW 100 and UW 100 which were made of 0.6 ± 0.06 mm thick cold bent galvanized steel in accordance with standard PN-EN 14195 [1.7], and
- profiles U 100/80, U 100/100, U 100/120, U 100/140, two angle elements 2L 100/120 or 2L 100/140 made of 1 ± 0.06 mm thick steel.

The vertical profiles placed around the perimeter – profiles CW 100 – are fixed to the side walls (side elements) while the bottom horizontal profiles placed around the perimeter – profiles UW 100 – are fixed to the floor by means of steel dowels of the minimum dimensions of $\varnothing 6 \times 40$ mm, placed at most every 80 cm (for details please see Figure 14).

The rules used for selecting the type of the top connection between the wall and the ceiling/roof (sliding connection, extended sliding connection) depending on the design deflection of the ceiling/roof during fire and the design vertical movement of the top of a pillar during fire are presented in item 2.10.

The following top perimeter profiles: profiles U 100/80, U 100/100, U 100/120 or U 100/140, are fixed to the ceiling/roof by means of:

- steel dowels of the minimum dimensions of $\varnothing 6 \times 40$ mm, placed at most every 80 cm (for details please see Figures 2d and 6c),
- steel dowels of the minimum dimensions of $\varnothing 6 \times 120$ mm, placed at most every 80 cm, through five layers of strips made of 12.5 mm thick gypsum plasterboards or through four layers of strips made of 15 mm thick gypsum plasterboards (for details please see Figures 6a and 6b).

The following top perimeter profiles: double angle elements 2L 100/120 or 2L 100/140, are fixed to the ceiling/roof by means of:

- steel dowels of the minimum dimensions of $\varnothing 6 \times 40$ mm, placed in two rows and at most every 80 cm (for details please see Figure 10c),
- steel dowels of the minimum dimensions of $\varnothing 6 \times 120$ mm, placed in two rows and at most every 80 cm, through five layers of strips made of 12.5 mm thick gypsum plasterboards or through four layers of strips made of 15 mm thick gypsum plasterboards (for details please see Figures 10a and 10b).

Sealing tape NORGIPS 100 is placed between the perimeter steel profiles and the ceiling/roof, floor and side walls.

Vertical posts are made of two profiles CW 100 which adjoin to each other at their webs. These profiles are connected with one another by means of screws with self-drilling endings NORGIPS $\varnothing 3.5 \times 9.5$ mm placed approximately every 50 cm in a staggered arrangement.

The posts are pushed in the inside of the horizontal perimeter profiles (top and bottom) every 40 cm or every 41.7 cm.

Profiles CW 100 can be connected with one another in such a way that their endings are connected (see Figure 15).

The walls are double sided covered with three layers of the following gypsum plasterboards meeting the requirements presented in standard PN-EN 520 [1.9]: NORGIPS S (fireproof) GKF type DF, NORGIPS S (fireproof and impregnated) GKFI type DFH2, or NORGIPS S Acoustic Super type

DFH2IR. The aforementioned gypsum plasterboards are 15 mm thick and the declared minimum surface density of the plasterboards is as follows:

- NORGIPS (fireproof) GKF type DF – 12.1 kg/m²,
- NORGIPS (fireproof and impregnated) GKFI type DFH2 – 12.1 kg/m²,
- NORGIPS Acoustic Super type DFH2IR – 13.5 kg/m².

The applied gypsum plasterboards are placed and fixed vertically. The vertical edges of the gypsum plasterboards are placed on the posts or on the vertical perimeter profiles of the framework.

The first layer of the boards is fixed to profiles UW 100 (the bottom perimeter profile) and profiles CW 100 (posts and vertical perimeter profiles) by means of screws NORGIPS Ø 3.5 x 25 mm placed at most every 75 cm. The second layer of the boards is fixed by means of screws NORGIPS Ø 3.5 x 35 mm placed at most every 50 cm. The third layer of the boards is fixed by means of screws NORGIPS Ø 3.5 x 55 mm placed at most every 25 cm. The boards are fixed in such a way that in the first layer of the lining of the wall, for each post, there are no vertical connections made from two sides of the wall.

The vertical connections from two sides of the walls in the first layers of the wall lining are shifted in relation to one another by 40 cm (41.7 cm). The horizontal connections in the first layer of the boards are shifted in relation to the horizontal connections between the adjacent boards of this layer by at least 40 cm.

The vertical connections in the second layer of the lining are shifted in relation to the vertical connections in the first layer of this lining by 40 cm (41.7 cm). The horizontal connections in the second layer of the boards are shifted in relation to the horizontal connections between the adjacent boards of this layer by at least 40 cm. The horizontal connections in the second layer of the lining are shifted in relation to the horizontal connections in the first layer of the lining by at least 40 cm.

The vertical connections in the third layer of the lining are shifted in relation to the vertical connections in the second layer of this lining by 40 cm (41.7 cm). The horizontal connections in the third layer of the boards are shifted in relation to the horizontal connections between the adjacent boards of this layer by at least 40 cm. The horizontal connections in the third layer of the lining are shifted in relation to the horizontal connections in the second layer of the lining by at least 40 cm.

Screw heads, the vertical and horizontal connections between the boards as well as perimeter sealing of each layer of the boards are covered with putty NORGIPS Start or NORGIPS Super Filler, while the vertical and horizontal connections in the third (external) layers of the boards are additionally reinforced with interfacing or mesh, reinforcing tape NORGIPS made of glass fibre.

The walls can be filled with mineral glass or rock wool (the maximum thickness of the wool used: 100 mm, the density of the wool used: 15 – 50 kg/m³). It is permitted to use no insulation made of mineral wool, i.e. to leave the inside of the wall empty and filled only with air.

Electric cables and wall boxes for electric installations can be installed in the wall, in accordance with Figure 16.

2.10 Connection between the walls and the ceiling/roof

The top connections between the high walls manufactured by NORGIPS Sp. z o.o. and the ceiling should be designed individually and in such a way that:

- it is guaranteed that the posts will not fall out from the horizontal perimeter profiles (when the top of the post moves down) and
- there is no possibility of vertical interaction between the ceiling and the posts (when the top of the post moves up or/and the ceiling deflects from its original position).

The connection between the wall and the ceiling should be one of the following types (variants):

- sliding, see Figures 2, 3c, 4c, 5c, 6c, 7c, 8c, 9c, 10c,
- extended sliding through five layers of 12.5 mm thick gypsum plasterboards or through four layers of 15 mm thick gypsum plasterboards, see Figures 3a, 3b, 4a, 4b, 5a, 5b, 6a, 6b, 7a, 7b, 8a, 8b, 9a, 9b, 10a and 10b.

The type (variant) of the connection should take into account the following:

- fire resistance class of the wall (duration of fire)
- design deflection of the ceiling, Δy_f , during fire, after elapsing of the time corresponding to the fire resistance class of the wall and design vertical movement of the top of the post, Δv_f , during fire, after elapsing of the same time (note: deflection of the ceiling, Δy_f , is positive; vertical movement of the top of the post, Δv_f , is positive if the post moves up and negative if the post moves down).

While selecting the type (variant) of the connection and the scope of the vertical movement of the post, one should meet the following conditions:

$$\Delta v_f + \Delta y_f \leq a \text{ (movement of the top of the post upwards) and}$$

$$\Delta v_f + b > 0 \text{ (movement of the top of the post downwards).}$$

The connection between the walls and the ceiling/roof should be selected taking into account the foreseen design deflection of the ceiling/roof during fire (Figure 1).

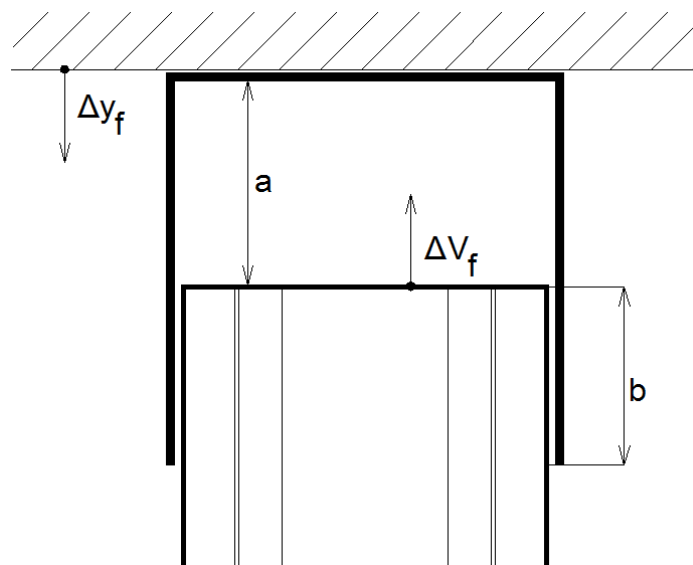

Figure 1. Deflections and dimensions

The type (variant) of the connection between the wall and the ceiling and dimensions “a” and “b” during installation of posts CW 100 should be selected based on the data presented in Table 1.

Table 1

Δy_f ceiling [mm] \ Δv_f post [mm]	0	10	20	30	40
0	U 100/100 a=30 b=70	U 100/100 a=30 b=70	U 100/100 a=30 b=70	U 100/100 a=30 b=70	U 100/100 a=40 b=60
10	U 100/100 a=30 b=70	U 100/100 a=30 b=70	U 100/100 a=30 b=70	U 100/100 a=40 b=60	U 100/100 a=50 b=50
20	U 100/100 a=30 b=70	U 100/100 a=30 b=70	U 100/100 a=40 b=60	U 100/100 a=50 b=50	U 100/120 a=60 b=60
30	U 100/100 a=30 b=70	U 100/100 a=40 b=60	U 100/100 a=50 b=50	U 100/120 a=60 b=60	U 100/140 a=70 b=70
40	U 100/100 a=40 b=60	U 100/100 a=50 b=50	U 100/120 a=60 b=60	2L 100/140 a=70 b=70	2L 100/140 a=80 b=60
50	U 100/100 a=50 b=50	U 100/120 a=60 b=60	U 100/120 a=70 b=50	2L 100/140 a=80 b=60	2L 100/140 a=90 b=50

If design calculations for fire do not prove otherwise, the following should be assumed:

- movement of the top of the post upwards, Δv_f , according to Table 2,
- movement of the top of the post downwards, Δy_f , equal to $\Delta y_f \leq -50$ mm,
- deflection of the ceiling, Δy_f , downwards equal to the design deflection of the ceiling for normal conditions.

Table 2

Height of the wall H [m]	Movement of the top of the post upwards, Δv_f [mm]
6.00	20
7.00	25
8.00	30
9.00	35
10.00	40

The possible connections between the walls and the ceiling/roof are presented in Figures 2 – 10.

3. Fire resistance tests of the high walls

Fire resistance tests of the high walls, with steel frameworks and lining made of gypsum plasterboards manufactured by NORGIPS Sp. z o.o. were carried out by the Fire Tests Laboratory of the Building Research Institute (Instytut Techniki Budowlanej).

Test reports: LP01-06041/14/R21NP, LP-677.1/03, LP-677.2/03, LP-677.3/03, LP-677.4/03, LP-677.5/03, LP-677.6/03 [1.8], [1.11].

4. Fire resistance classification of the high walls

Based on the analysis of the fire resistance test results indicated in item 3, the following products:

high walls, with steel frameworks and lining made of gypsum plasterboards manufactured by NORGIPS Sp. z o.o.

prepared in accordance with the technical description presented in item 2, are classified in accordance with the criteria presented in standard PN-EN 13501-2:2016-07 [1.3] as belonging to the fire resistance classes indicated in Table 3 in Annex 2.

5. High walls used as separation from fire

Non-loadbearing high walls prepared in accordance with the technical description presented in item 2 can be used as separation from fire meeting the REI fire resistance criteria if the following conditions are met:

- the walls are fixed to or placed on the construction meeting the criteria for a fire resistance class equal to or higher than the fire resistance class (EI) of the wall,
- the walls are not subjected to the mechanical load generated by the construction of the building,
- the walls are fixed to the elements of the building in accordance with the building project.

6. Validity

The classification presented in item 4 is valid until 31.12.2025 on the condition that there are no changes in the construction or materials of the classified products.

Annex 1 – Drawings presenting the high walls, with steel frameworks and lining made of gypsum plasterboards manufactured by NORGIPS Sp. z o.o.

Annex 2 – Table 3 presenting the classification of the high walls, with steel frameworks and lining made of gypsum plasterboards manufactured by NORGIPS Sp. z o.o.

Classification No. LBO – 061 – KZ/20E

Annex 1

Drawings presenting the high walls, with steel frameworks and lining made of gypsum plasterboards manufactured by NORGIPS Sp. z o.o.

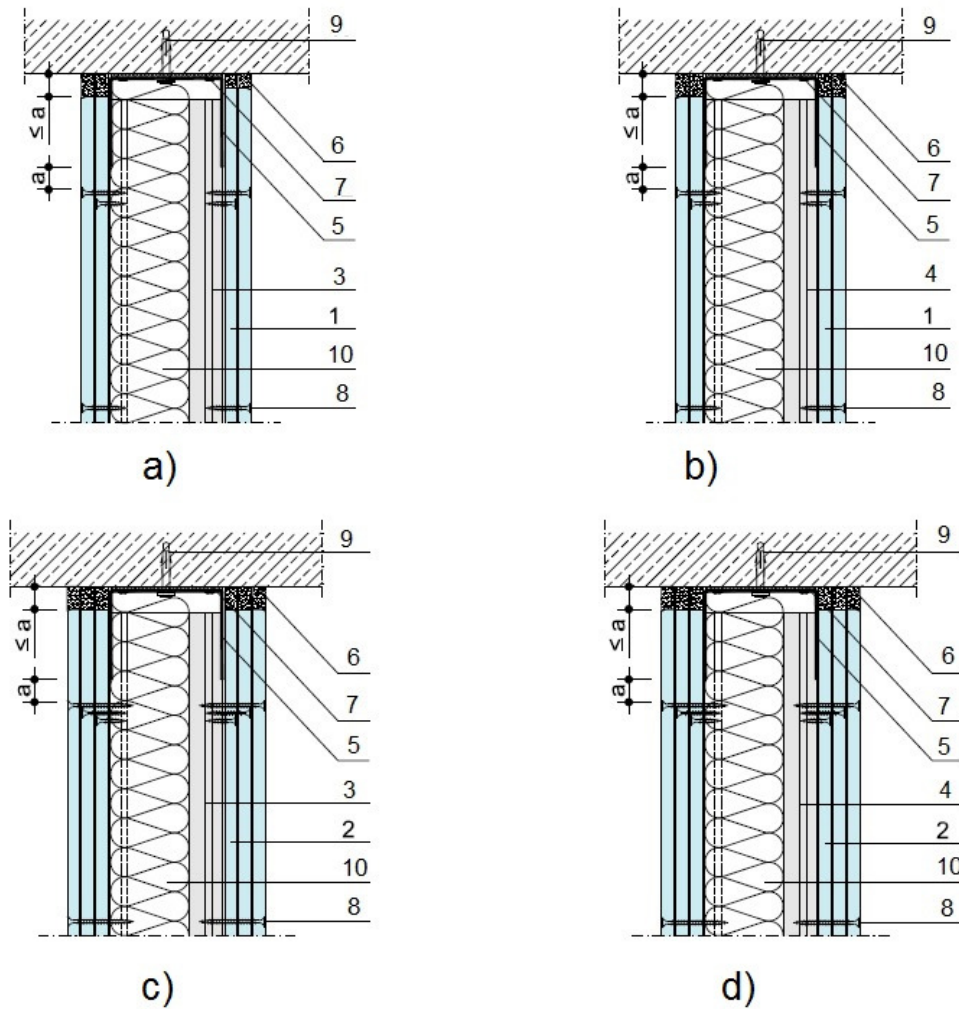

1. Gypsum plasterboards Norgips type DF 2 x 12.5 mm
2. Gypsum plasterboards Norgips type DF 3 x 12.5 mm or 3 x 15 mm
3. Profile Norgips CW 100 placed every 30 cm
4. Double profile Norgips CW 100 placed every 60 cm or 40 cm
5. Profile U, minimum dimensions: 100 x 80 mm
6. Putty Norgips
7. Sealing tape Norgips 100
8. Screws Norgips for gypsum plasterboards
9. Steel dowel, minimum dimensions: 6 x 40 mm
10. Empty space or mineral wool (maximum thickness of the wool: 100 mm, density of the wool: 15 – 50 kg/m³)

Figure 2. Connection with the ceiling, the value of “a” as per Table 1.
Application as per the description in item 2

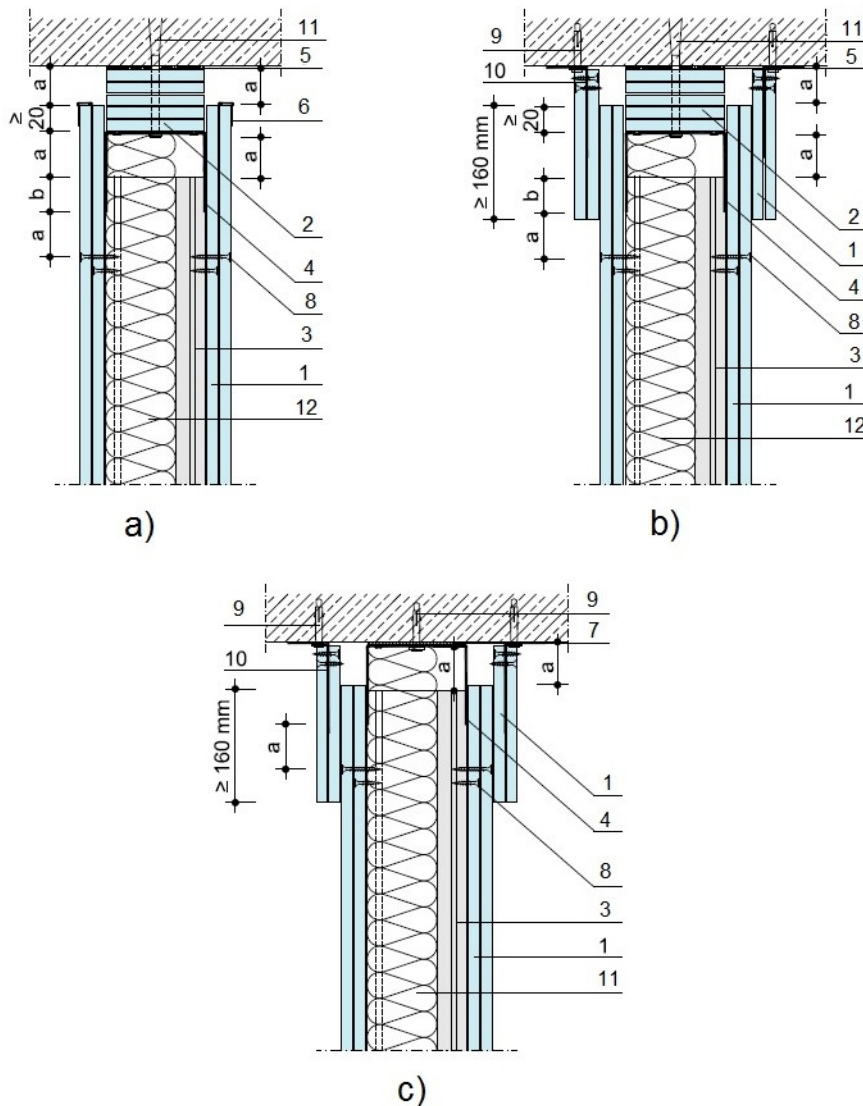

1. Gypsum plasterboards Norgips type DF 2 x 12.5 mm
2. Strips of gypsum plasterboards Norgips type DF 5 x 12.5 mm or 4 x 15 mm
3. Profile Norgips CW 100 placed every 30 cm
4. Profile U, minimum dimensions: 100 x 80 mm
5. Putty Norgips
6. Protection angle element (recommended)
7. Sealing tape Norgips 100
8. Screws Norgips for gypsum plasterboards
9. Steel dowel, minimum dimensions: 6 x 40 mm
10. Steel angle element, minimum dimensions: 50 x 50 mm
11. Steel dowel, minimum dimensions: 6 x 120 mm
12. Empty space or mineral wool (maximum thickness of the wool: 100 mm, density of the wool: 15 – 50 kg/m³)

Figure 3. Sliding connection with the ceiling – the construction made of single profiles CW, 2-layer lining, the values of “a” and “b” as per Table 1.
Application as per the description in item 2

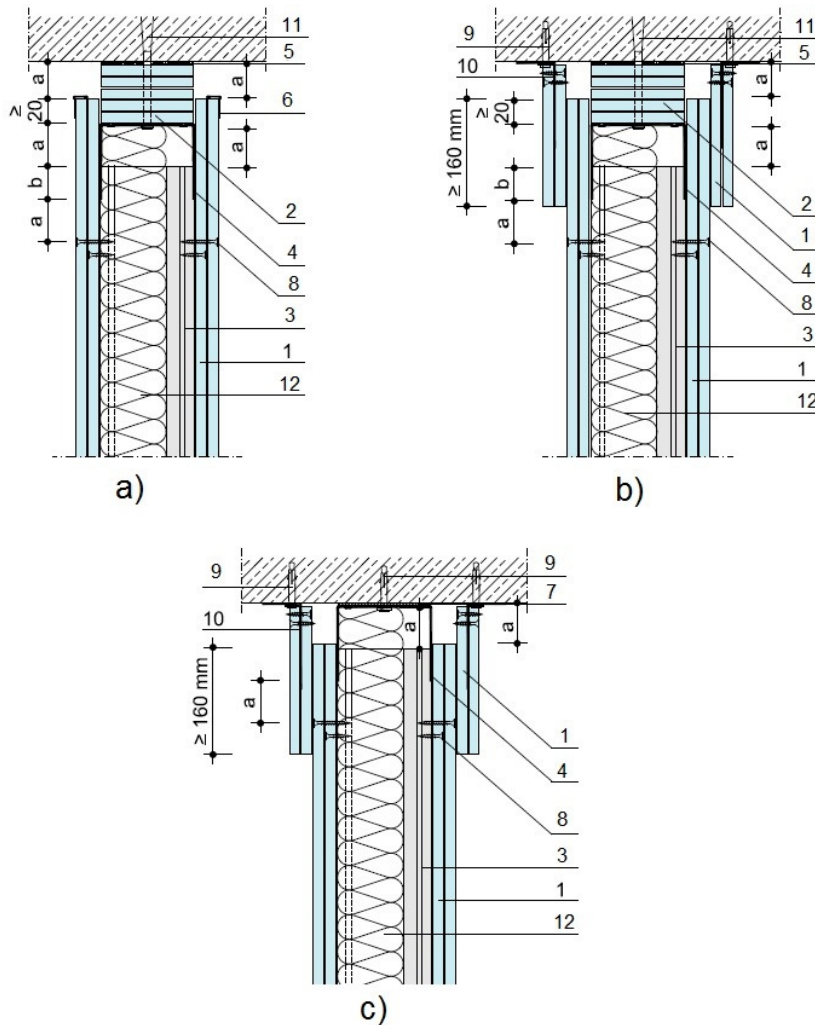

1. Gypsum plasterboards Norgips type DF 2 x 12.5 mm
2. Strips of gypsum plasterboards Norgips type DF 5 x 12.5 mm or 4 x 15 mm
3. Double profile Norgips CW 100 placed every 60 cm or every 40 cm
4. Profile U, minimum dimensions: 100 x 80 mm
5. Putty Norgips
6. Protection angle element (recommended)
7. Sealing tape Norgips 100
8. Screws Norgips for gypsum plasterboards
9. Steel dowel, minimum dimensions: 6 x 40 mm
10. Steel angle element, minimum dimensions: 50 x 50 mm
11. Steel dowel, minimum dimensions: 6 x 120 mm
12. Empty space or mineral wool (maximum thickness of the wool: 100 mm, density of the wool: 15 – 50 kg/m³)

Figure 4. Sliding connection with the ceiling – the construction made of double profiles CW, 2-layer lining, the values of “a” and “b” as per Table 1.
Application as per the description in item 2

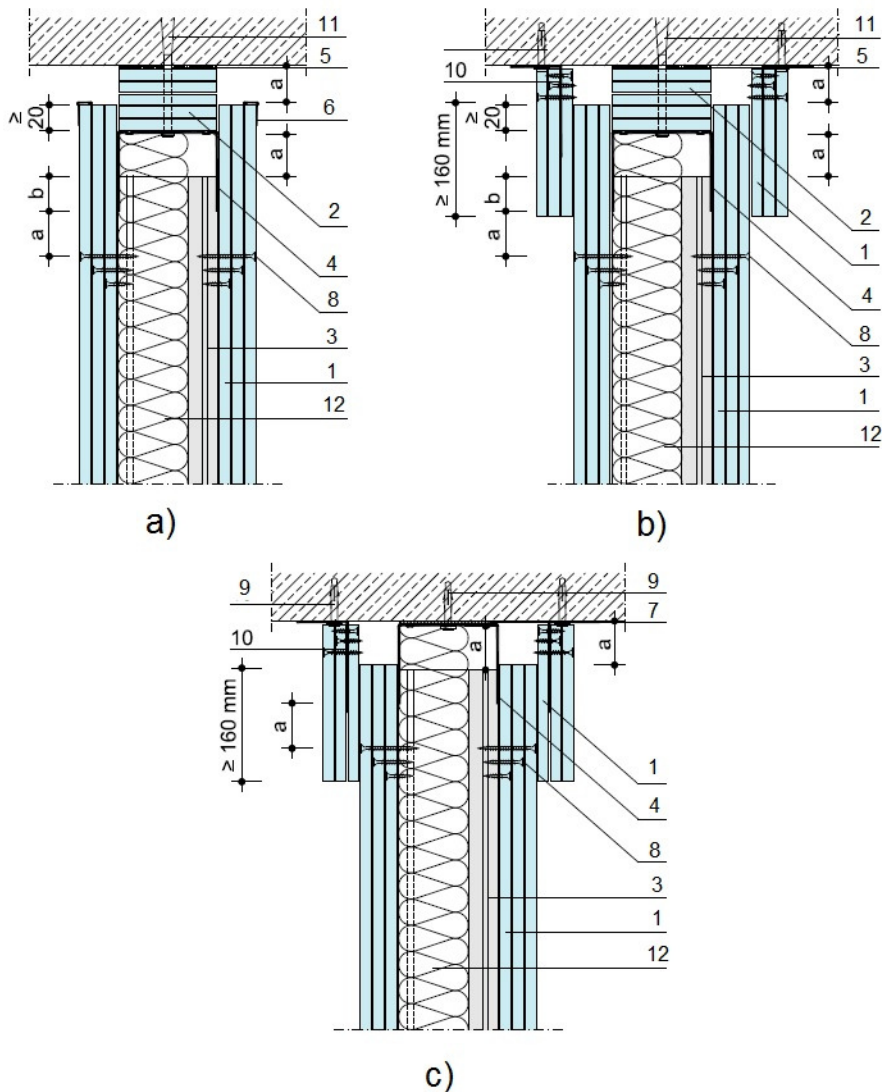

1. Gypsum plasterboards Norgips type DF 3 x 12.5 mm or 3 x 15 mm
2. Strips of gypsum plasterboards Norgips type DF 5 x 12.5 mm or 4 x 15 mm
3. Profile Norgips CW 100 placed every 30 cm
4. Profile U, minimum dimensions: 100 x 80 mm
5. Putty Norgips
6. Protection angle element (recommended)
7. Sealing tape Norgips 100
8. Screws Norgips for gypsum plasterboards
9. Steel dowel, minimum dimensions: 6 x 40 mm
10. Steel angle element, minimum dimensions: 50 x 50 mm
11. Steel dowel, minimum dimensions: 6 x 120 mm
12. Empty space or mineral wool (maximum thickness of the wool: 100 mm, density of the wool: 15 – 50 kg/m³)

Figure 5. Sliding connection with the ceiling – the construction made of single profiles CW, 3-layer lining, the values of “a” and “b” as per Table 1.
Application as per the description in item 2

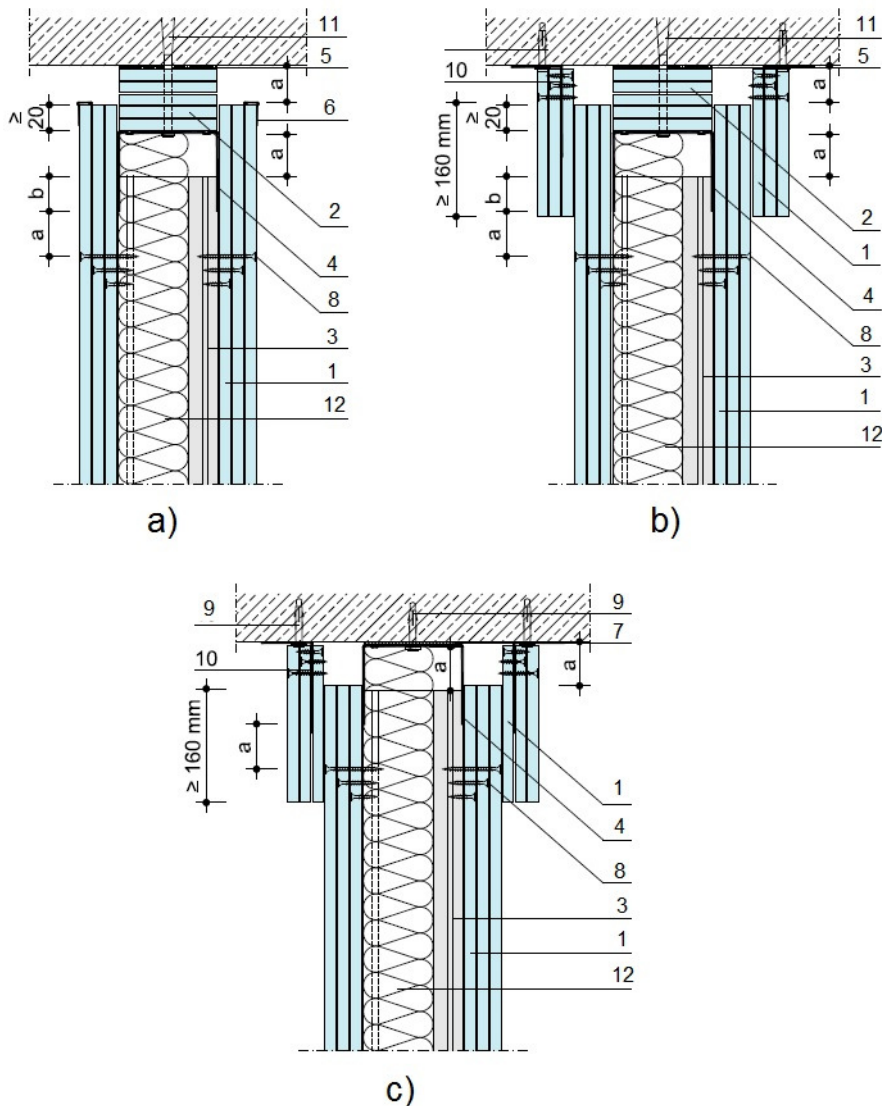

1. Gypsum plasterboards Norgips type DF 3 x 12.5 mm or 3 x 15 mm
2. Strips of gypsum plasterboards Norgips type DF 5 x 12.5 mm or 4 x 15 mm
3. Double profile Norgips CW 100 placed every 60 cm or every 40 cm
4. Profile U, minimum dimensions: 100 x 80 mm
5. Putty Norgips
6. Protection angle element (recommended)
7. Sealing tape Norgips 100
8. Screws Norgips for gypsum plasterboards
9. Steel dowel, minimum dimensions: 6 x 40 mm
10. Steel angle element, minimum dimensions: 50 x 50 mm
11. Steel dowel, minimum dimensions: 6 x 120 mm
12. Empty space or mineral wool (maximum thickness of the wool: 100 mm, density of the wool: 15 – 50 kg/m³)

Figure 6. Sliding connection with the ceiling – the construction made of double profiles CW, 3-layer lining, the values of “a” as per Table 1.
Application as per the description in item 2

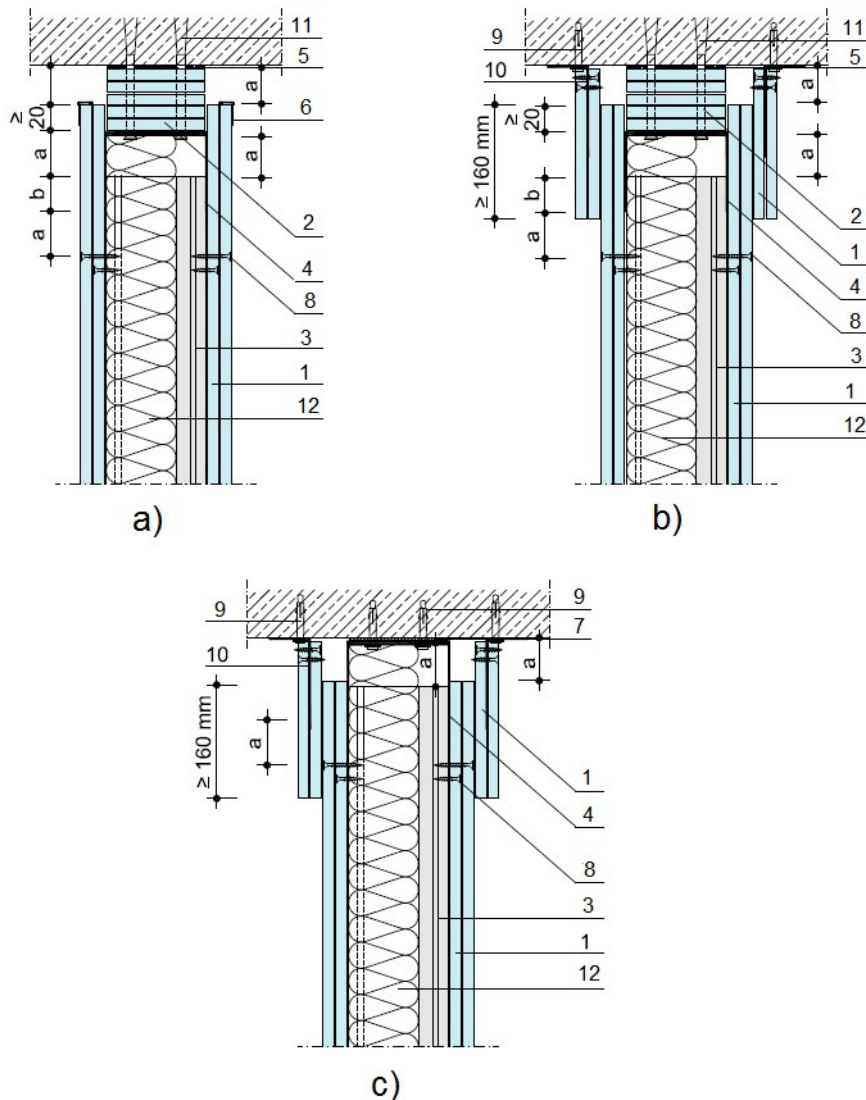

1. Gypsum plasterboards Norgips type DF 2 x 12.5 mm
2. Strips of gypsum plasterboards Norgips type DF 5 x 12.5 mm or 4 x 15 mm
3. Profile Norgips CW 100 placed every 30 cm
4. 2 x angle element L, minimum dimensions: 100 x 120 mm
5. Putty Norgips
6. Protection angle element (recommended)
7. Sealing tape Norgips 100
8. Screws Norgips for gypsum plasterboards
9. Steel dowel, minimum dimensions: 6 x 40 mm
10. Steel angle element, minimum dimensions: 50 x 50 mm
11. Steel dowel, minimum dimensions: 6 x 120 mm
12. Empty space or mineral wool (maximum thickness of the wool: 100 mm, density of the wool: 15 – 50 kg/m³)

Figure 7. Sliding connection with the ceiling – the construction made of single profiles CW, 2-layer lining, the values of “a” and “b” as per Table 1.
Application as per the description in item 2

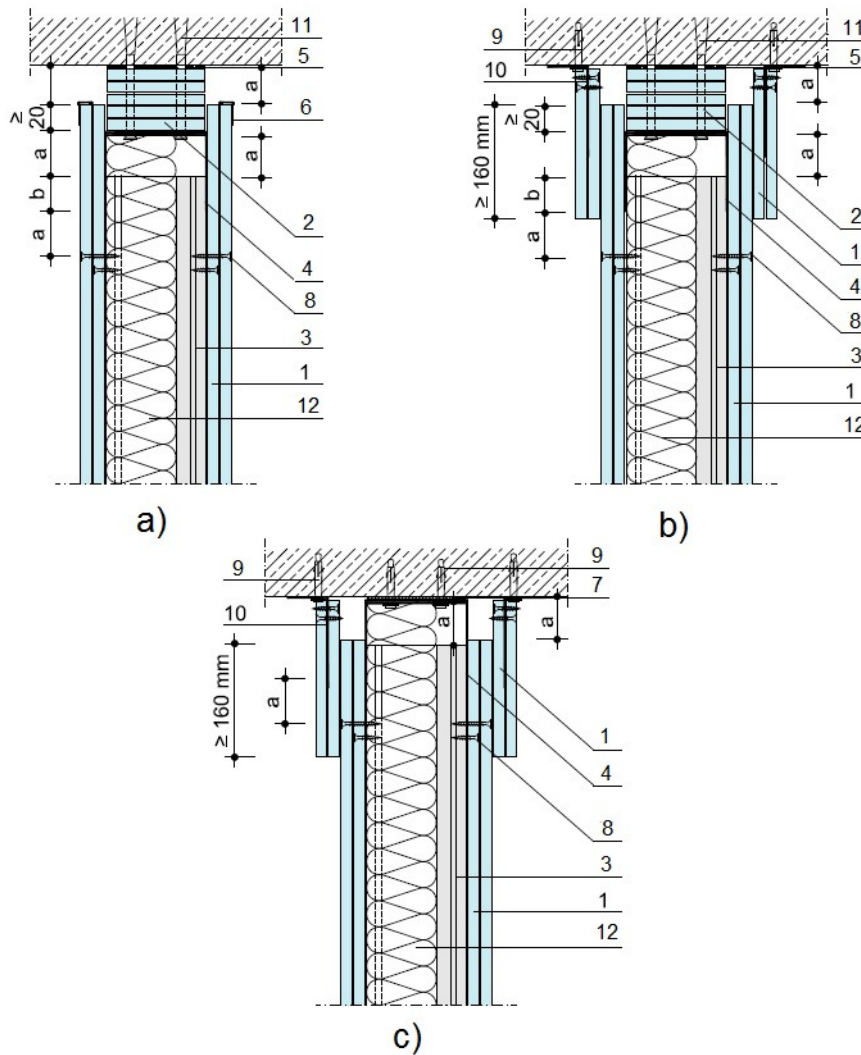

1. Gypsum plasterboards Norgips type DF 2 x 12.5 mm
2. Strips of gypsum plasterboards Norgips type DF 5 x 12.5 mm or 4 x 15 mm
3. Double profile Norgips CW 100 placed every 60 cm or every 40 cm
4. 2 x angle element L, minimum dimensions: 100 x 120 mm
5. Putty Norgips
6. Protection angle element (recommended)
7. Sealing tape Norgips 100
8. Screws Norgips for gypsum plasterboards
9. Steel dowel, minimum dimensions: 6 x 40 mm
10. Steel angle element, minimum dimensions: 50 x 50 mm
11. Steel dowel, minimum dimensions: 6 x 120 mm
12. Empty space or mineral wool (maximum thickness of the wool: 100 mm, density of the wool: 15 – 50 kg/m³)

Figure 8. Sliding connection with the ceiling – the construction made of double profiles CW, 2-layer lining, the values of “a” and “b” as per Table 1.
Application as per the description in item 2

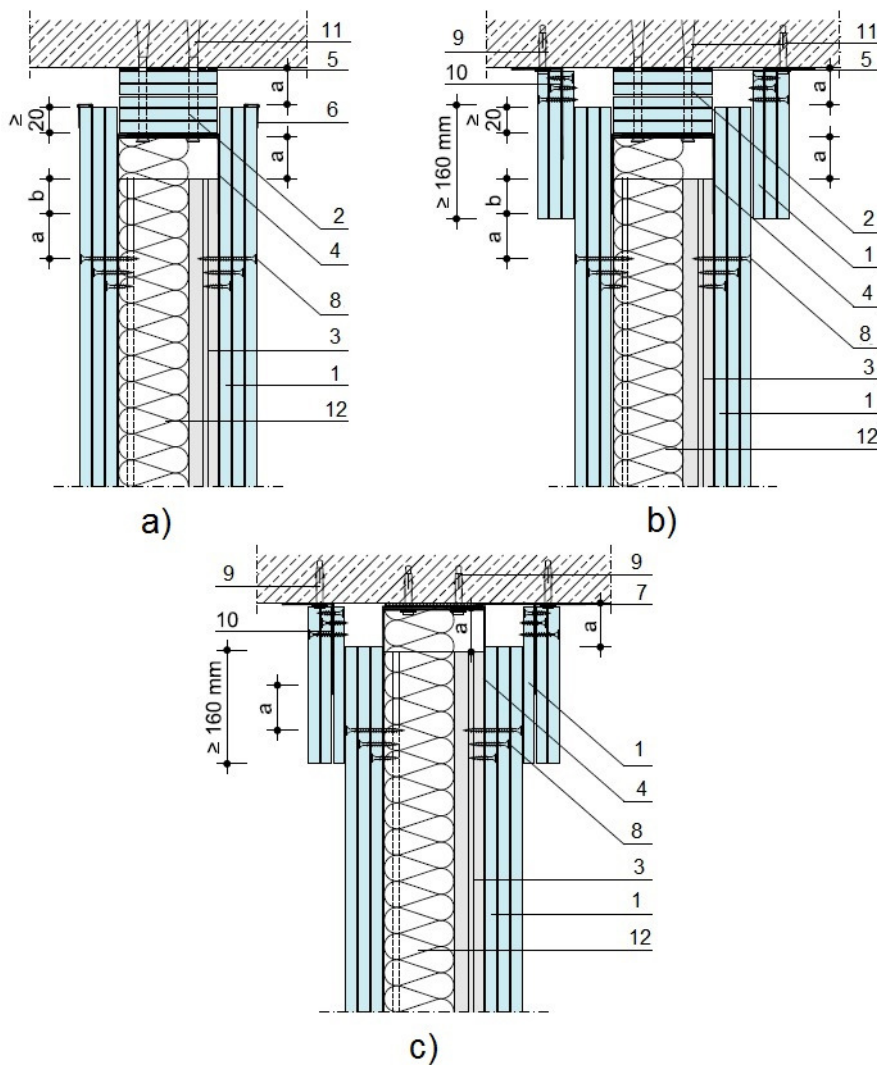

1. Gypsum plasterboards Norgips type DF 3 x 12.5 mm or 3 x 15 mm
2. Strips of gypsum plasterboards Norgips type DF 5 x 12.5 mm or 4 x 15 mm
3. Profile Norgips CW 100 placed every 30 cm
4. 2 x angle element L, minimum dimensions: 100 x 120 mm
5. Putty Norgips
6. Protection angle element (recommended)
7. Sealing tape Norgips 100
8. Screws Norgips for gypsum plasterboards
9. Steel dowel, minimum dimensions: 6 x 40 mm
10. Steel angle element, minimum dimensions: 50 x 50 mm
11. Steel dowel, minimum dimensions: 6 x 120 mm
12. Empty space or mineral wool (maximum thickness of the wool: 100 mm, density of the wool: 15 – 50 kg/m³)

Figure 9. Sliding connection with the ceiling – the construction made of single profiles CW, 3-layer lining, the values of “a” and “b” as per Table 1.
Application as per the description in item 2

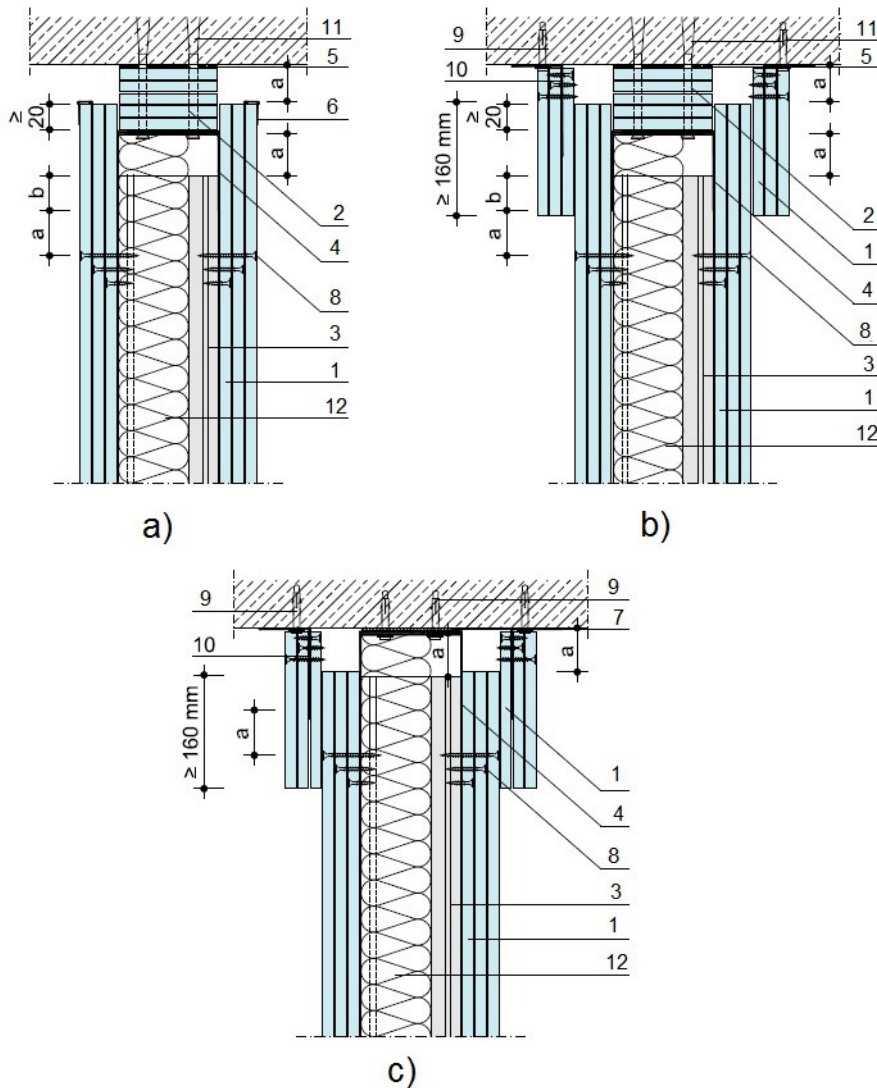

1. Gypsum plasterboards Norgips type DF 3 x 12.5 mm or 3 x 15 mm
2. Strips of gypsum plasterboards Norgips type DF 5 x 12.5 mm or 4 x 15 mm
3. Double profile Norgips CW 100 placed every 60 cm or every 40 cm
4. 2 x angle element L, minimum dimensions: 100 x 120 mm
5. Putty Norgips
6. Protection angle element (recommended)
7. Sealing tape Norgips 100
8. Screws Norgips for gypsum plasterboards
9. Steel dowel, minimum dimensions: 6 x 40 mm
10. Steel angle element, minimum dimensions: 50 x 50 mm
11. Steel dowel, minimum dimensions: 6 x 120 mm
12. Empty space or mineral wool (maximum thickness of the wool: 100 mm, density of the wool: 15 – 50 kg/m³)

Figure 10. Sliding connection with the ceiling – the construction made of double profiles CW, 3-layer lining, the values of “a” as per Table 1.
Application as per the description in item 2

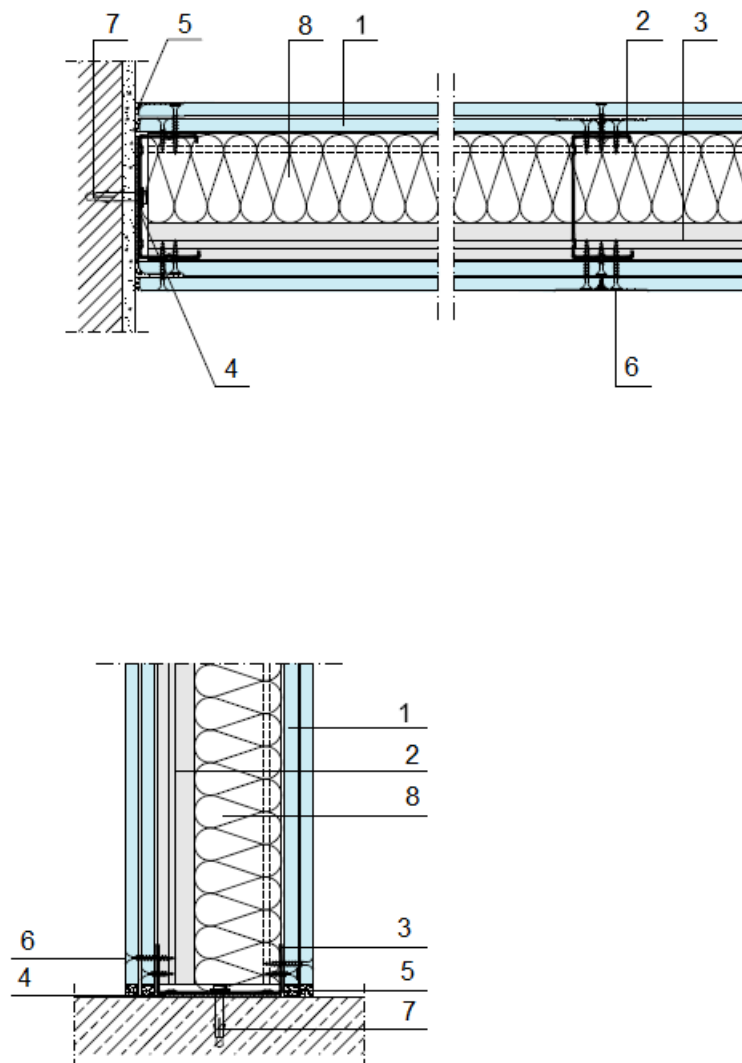

1. Gypsum plasterboards Norgips type DF 2 x 12.5 mm
2. Profile Norgips CW 100 placed every 30 cm
3. Profile Norgips UW 100
4. Sealing tape Norgips 100
5. Putty Norgips
6. Screws Norgips for gypsum plasterboards
7. Steel dowel, minimum dimensions: 6 x 40 mm
8. Empty space or mineral wool (maximum thickness of the wool: 100 mm, density of the wool: 15 – 50 kg/m³)

Figure 11. Connection with the massive wall and the floor.
Application as per the description in item 2

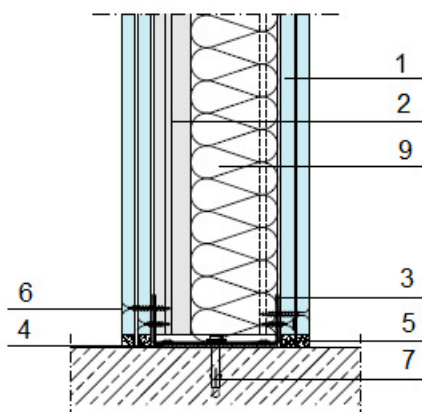
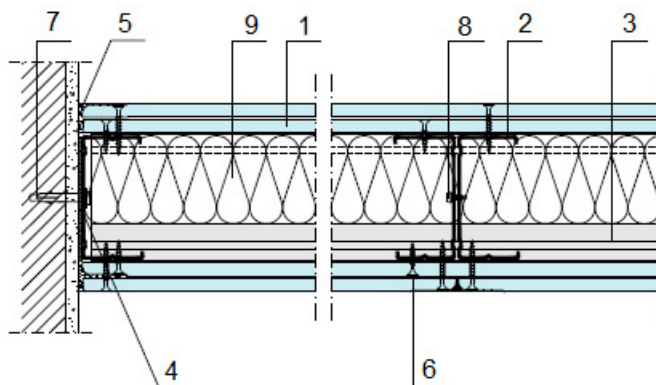

1. Gypsum plasterboards Norgips type DF 2 x 12.5 mm
2. Double profile Norgips CW 100 placed every 60 cm or every 40 cm
3. Profile Norgips UW 100
4. Sealing tape Norgips 100
5. Putty Norgips
6. Screws Norgips for gypsum plasterboards
7. Steel dowel, minimum dimensions: 6 x 40 mm
8. Screws Norgips with self-drilling endings 3.5 x 9.5 mm
9. Empty space or mineral wool (maximum thickness of the wool: 100 mm, density of the wool: 15 – 50 kg/m³)

Figure 12. Connection with the massive wall and the floor.
Application as per the description in item 2

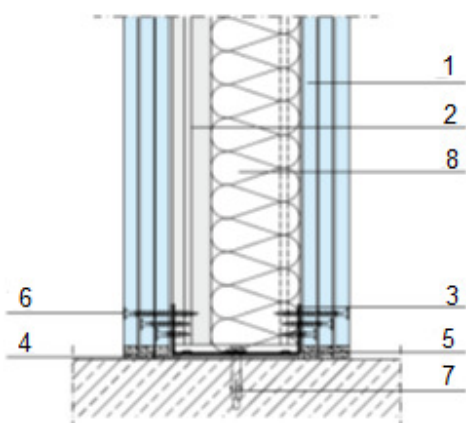
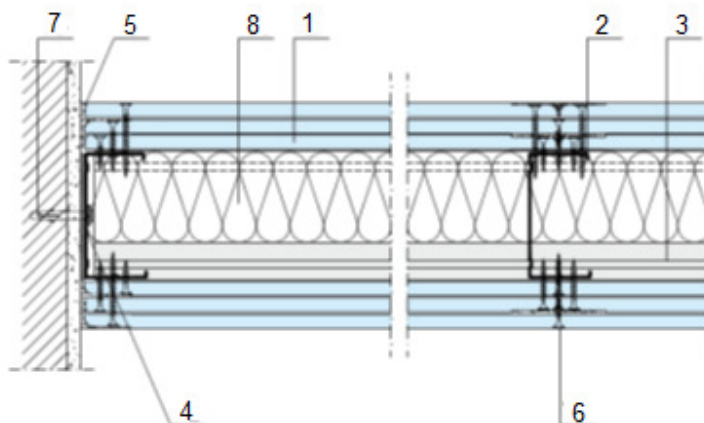

1. Gypsum plasterboards Norgips type DF 3 x 12.5 mm
2. Profile Norgips CW 100 placed every 60 cm or every 40 cm
3. Profile Norgips UW 100
4. Sealing tape Norgips 100
5. Putty Norgips
6. Screws Norgips for gypsum plasterboards
7. Steel dowel, minimum dimensions: 6 x 40 mm
8. Empty space or mineral wool (maximum thickness of the wool: 100 mm, density of the wool: 15 – 50 kg/m³)

Figure 13. Connection with the massive wall and the floor.
Application as per the description in item 2

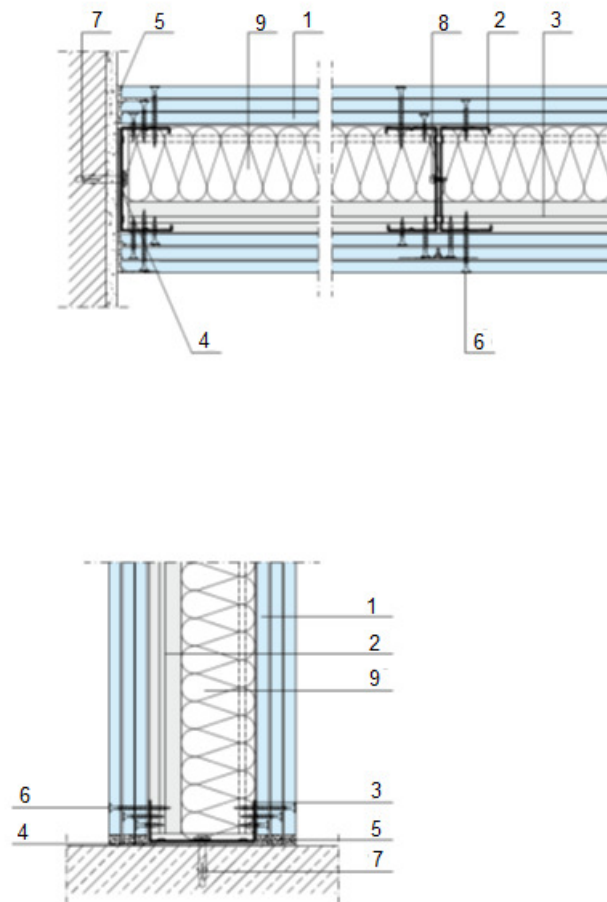

1. Gypsum plasterboards Norgips type DF 2 x 12.5 mm
2. Double profile Norgips CW 100 placed every 60 cm or every 40 cm
3. Profile Norgips UW 100
4. Sealing tape Norgips 100
5. Putty Norgips
6. Screws Norgips for gypsum plasterboards
7. Steel dowel, minimum dimensions: 6 x 40 mm
8. Screws Norgips with self-drilling endings 3.5 x 9.5 mm
9. Empty space or mineral wool (maximum thickness of the wool: 100 mm, density of the wool: 15 – 50 kg/m³)

Figure 14. Connection with the massive wall and the floor.
Application as per the description in item 2

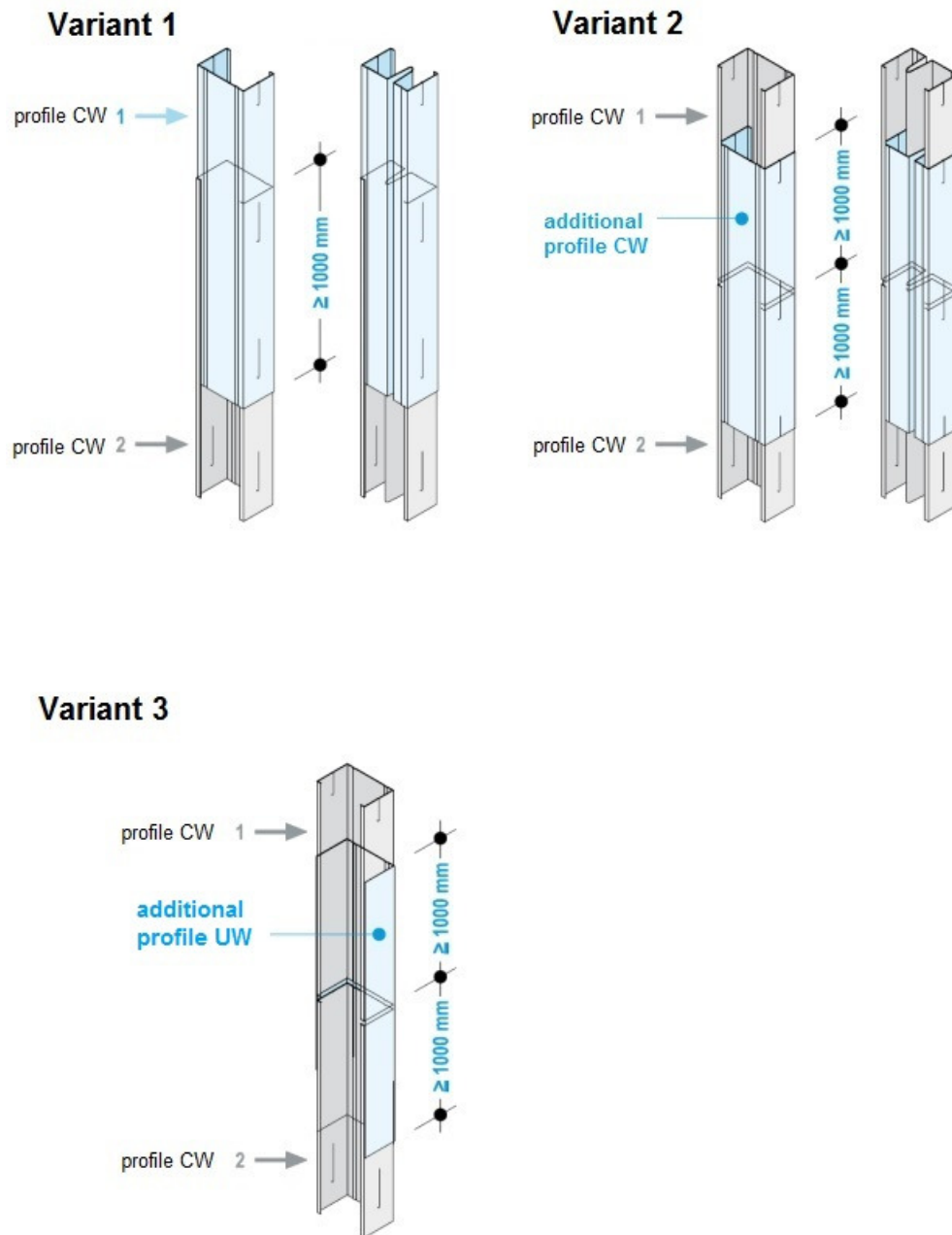
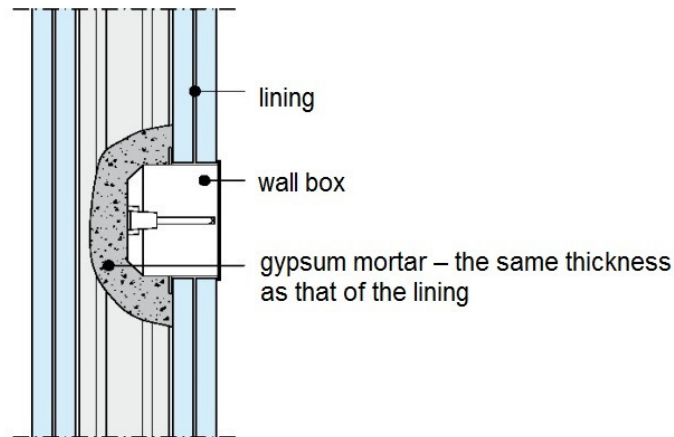

Figure 15. Extending profiles CW 100

Installation of wall boxes

with gypsum mortar



with gypsum plasterboards

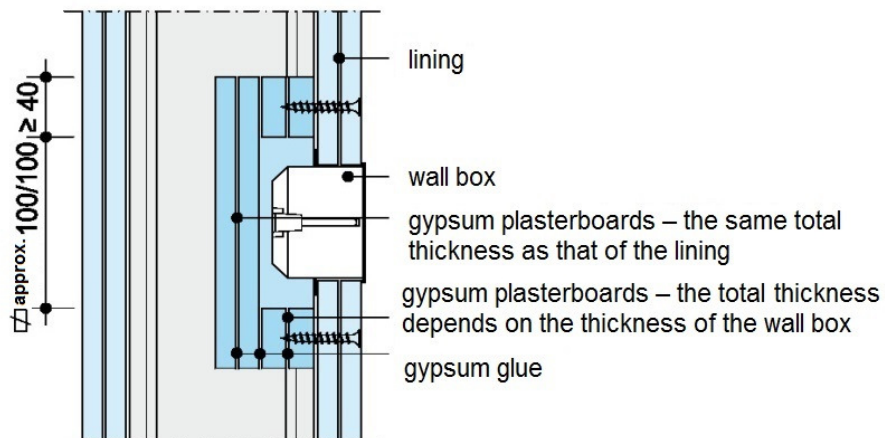

Figure 16 Installation of wall boxes

Classification No. LBO – 061 – KZ/20E

Annex 2

Table 3

Table 3. Fire resistance classification of walls manufactured by NORGIPS Sp. z o.o.

Walls as described in item:			Height of the wall, determined according to the rules specified in item 3.10 but not greater than	Fire resistance class
	Posts (type, placement)	Lining		
2.1	CW 100, doubled, every 600 mm	2 x 12.5 mm, oriented vertically	9.0 m	EI 60
2.2	CW 100, single, every 300 mm	2 x 12.5 mm, oriented vertically	9.0 m	EI 60
2.3	CW 100, doubled, every 400 mm	2 x 12.5 mm, oriented vertically	10.0 m	EI 60
2.4	CW 100, doubled, every 600 mm	3 x 12.5 mm, oriented vertically	9.0 m	EI 120
2.5	CW 100, single, every 300 mm	3 x 12.5 mm, oriented vertically	9.0 m	EI 120
2.6	CW 100, doubled, every 400 mm	3 x 12.5 mm, oriented vertically	10.0 m	EI 120
2.7	CW 100, doubled, every 600 mm	3 x 15 mm, oriented vertically	10.0 m	EI 120
2.8	CW 100, single, every 300 mm	3 x 15 mm, oriented vertically	10.0 m	EI 120
2.9	CW 100, doubled, every 400 mm	3 x 15 mm, oriented vertically	11.0 m	EI 120

Infill: empty space or mineral wool (glass or rock) of the density of 15 - 50 kg/m³