

# **NORGIPS®**

**PARTITION WALLS JOINTS - ASSEMBLY DETAILS**



## ***Partition walls joints - assembly details***

***NORGIPS solutions***





The NORGIPS Partition walls – assembly details catalogue is a set of necessary solutions dedicated to each contractor planning professional construction of **drywall materials**, aiming simultaneously at ensuring highest quality and appearance standards. The partition wall element connection methods take into account the comfort of use by ensuring high acoustic and fire safety parameters. Thus this NORGIPS catalogue is a perfect reference material for investors, designers and professional contractors.

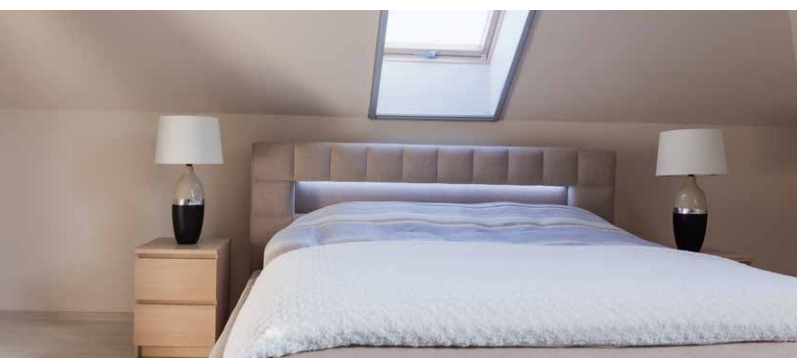
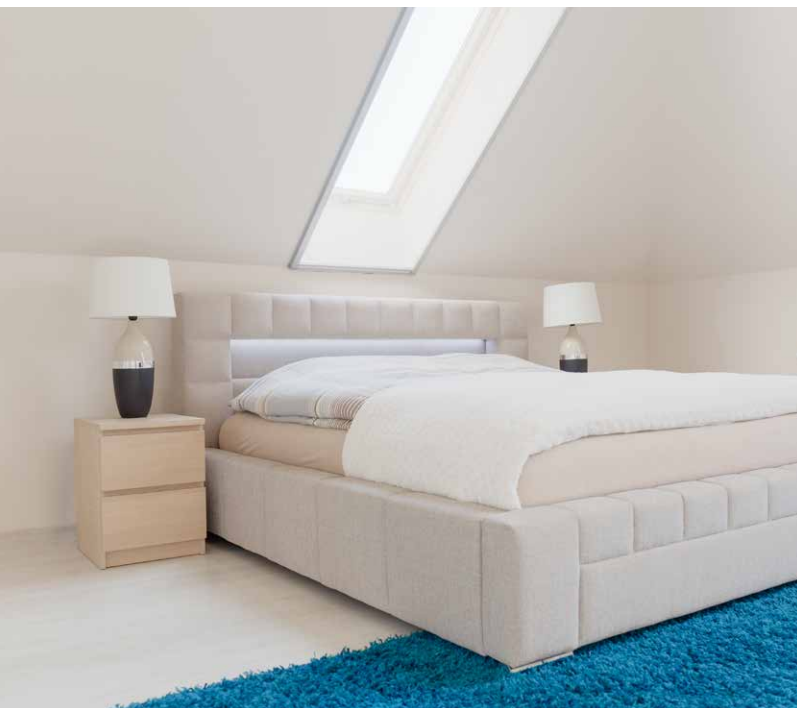

# You will make it with us

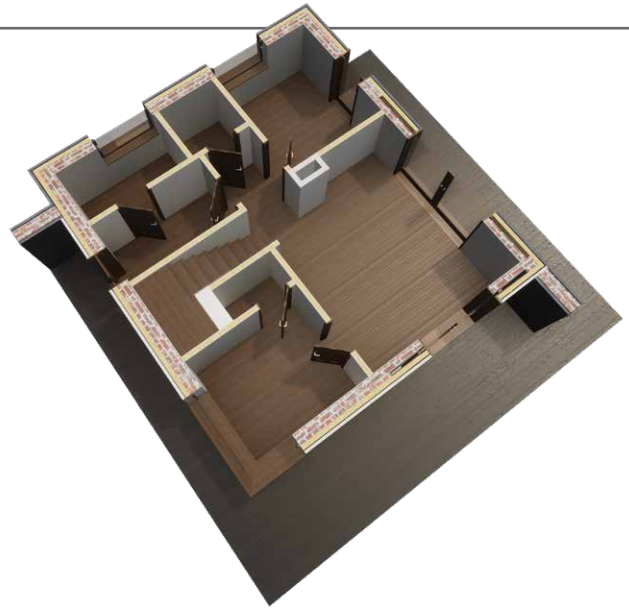

**Installation solutions**

**Lower and upper partition wall connection**

**Door openings**

**Wall-wall connections and expansions**

**Sanitary rooms**

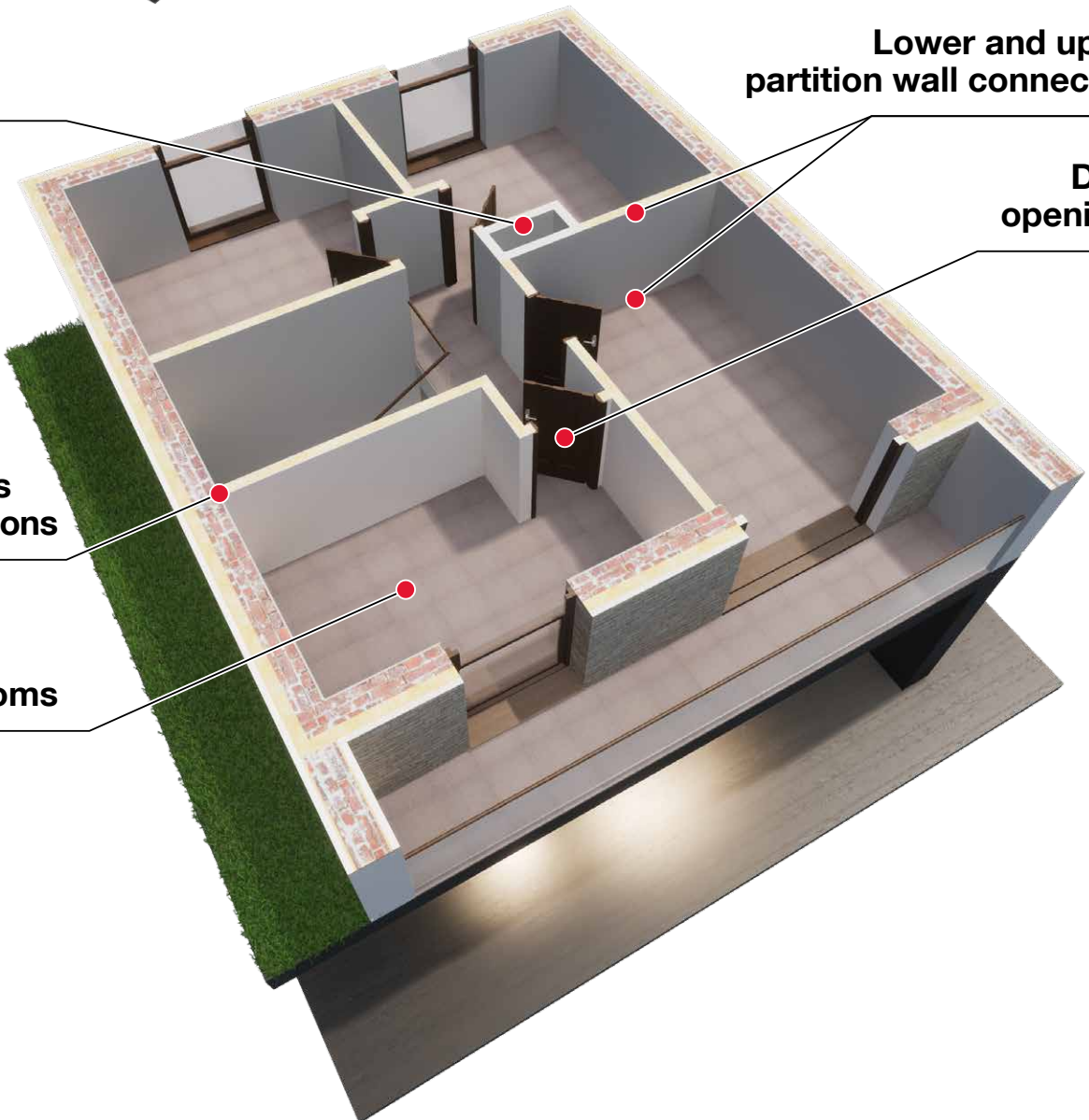

# UPPER JOINTS

## Connecting a NORGIPS partition wall with a ceiling

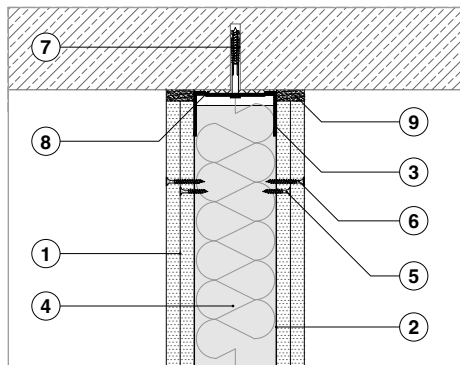

Fig. 1. Connecting a partition wall with a ceiling

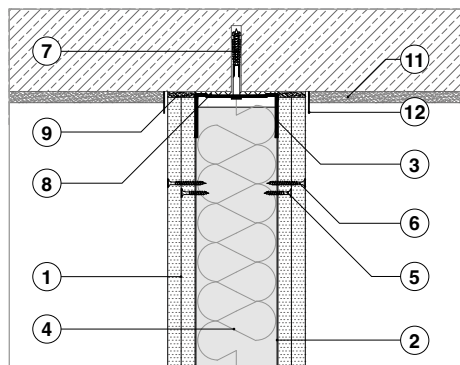

Fig. 2. Connecting a partition wall with a ceiling, and securing boards before applying plaster

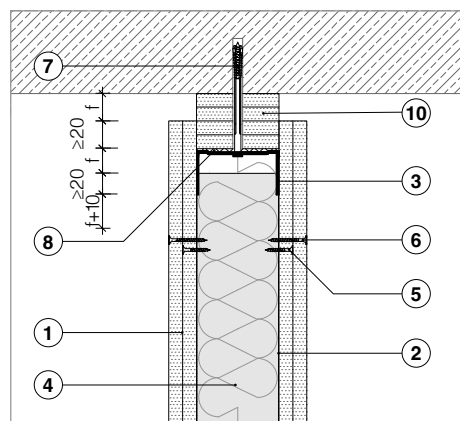
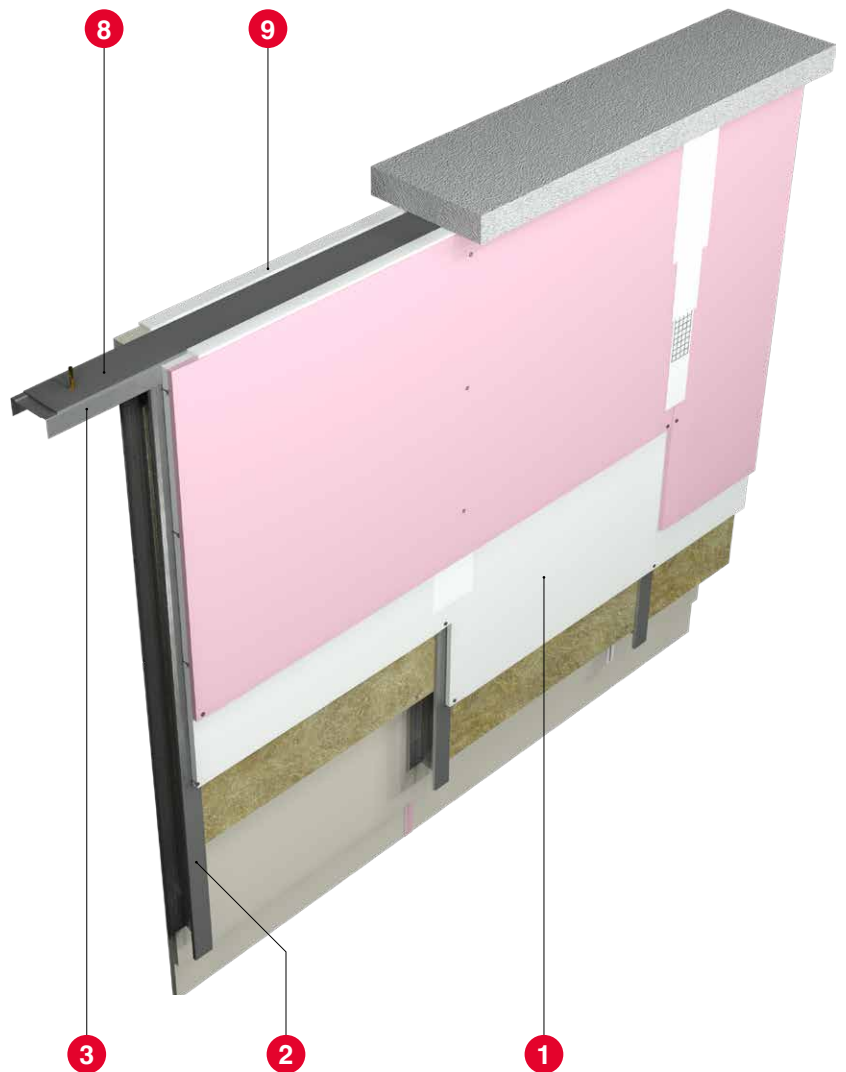

Fig. 3. Connecting a partition wall with a ceiling, with ceiling deflection up to 5 cm



### Construction elements:

1. NORGIPS plasterboard
2. NORGIPS CW profile
3. NORGIPS UW profile – for  $f \leq 20$  mm – standard version  
– for  $20$  mm  $< f < 50$  mm – special profile with a height of 80 mm
4. Mineral wool
5. NORGIPS 3.5 x 25 mm tapping screw
6. NORGIPS 3.5 x 35 mm tapping screw
7. Expansion stud or dowel
8. Foam sealing tape
9. NORGIPS gypsum joint filler
10. NORGIPS plasterboard strips
11. Plaster
12. Insulating tape

f – designed ceiling deflection

# UPPER JOINTS

Connecting a NORGIPS partition wall with a suspended ceiling or ceiling lining

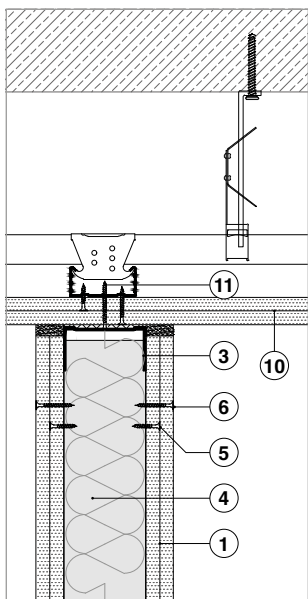
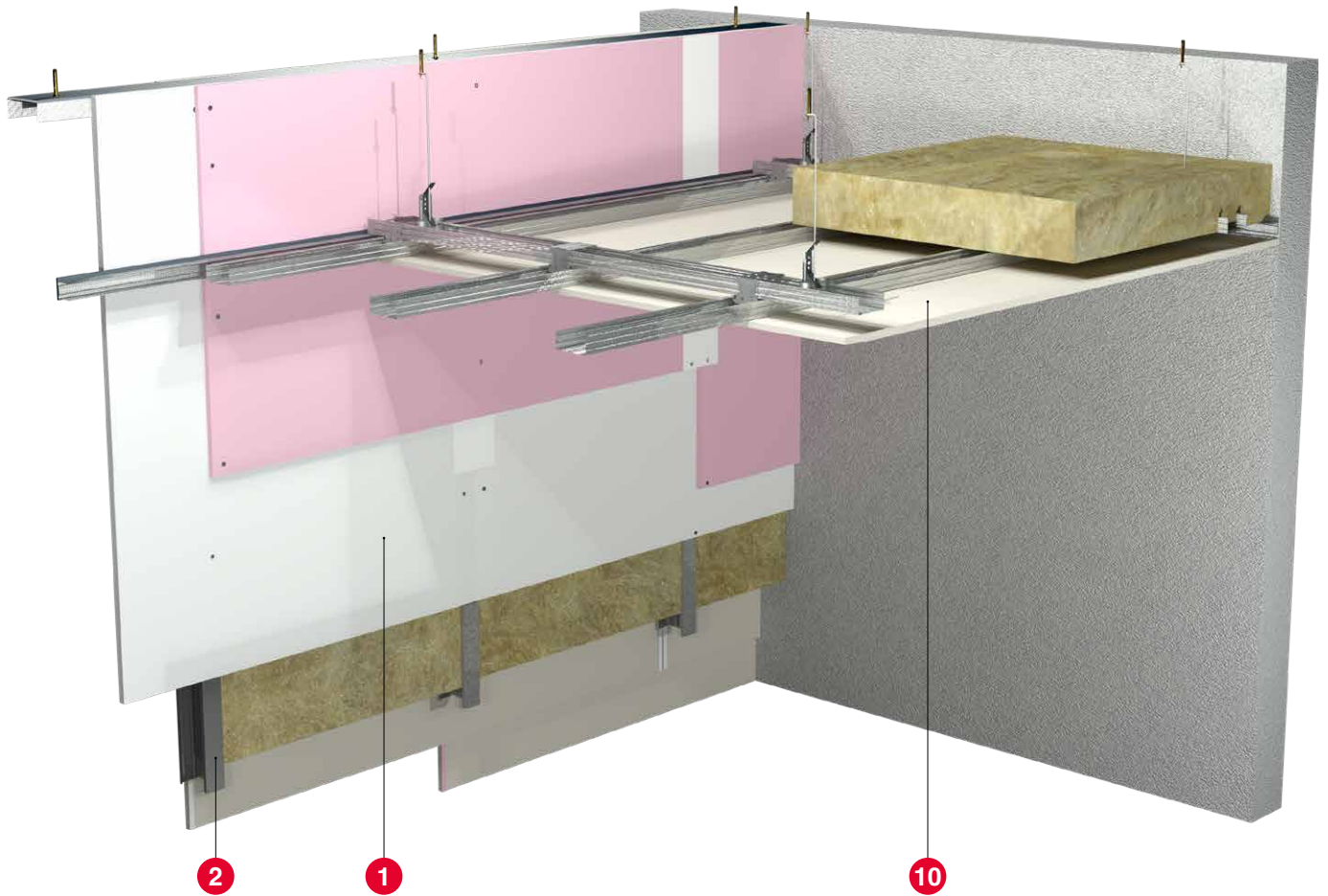

Fig. 4. Fastening a partition wall directly to a NORGIPS suspended ceiling

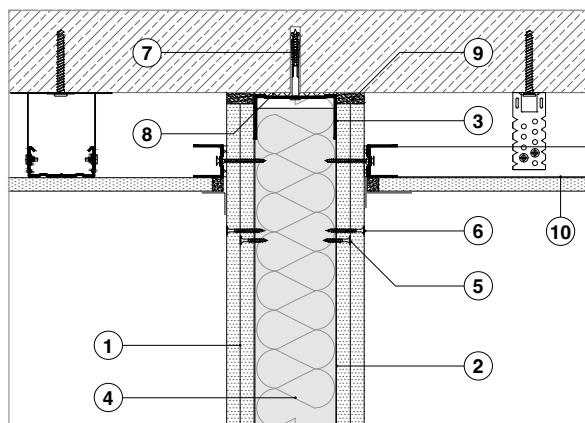

Fig. 5. Connecting a partition wall with NORGIPS ceiling lining

## Construction elements:

1. NORGIPS plasterboard
2. NORGIPS CW profile
3. NORGIPS UW profile
4. Mineral wool
5. NORGIPS 3.5 x 25 mm tapping screw
6. NORGIPS 3.5 x 35 mm tapping screw
7. Expansion stud or dowel
8. Foam sealing tape
9. NORGIPS gypsum joint filler
10. Ceiling cladding of NORGIPS suspended ceiling
11. Steel fastener, spaced every 400 mm and fixed to load-bearing profiles in a ceiling

# UPPER JOINTS

## Connecting a NORGIPS partition wall with trapezoidal sheet panels

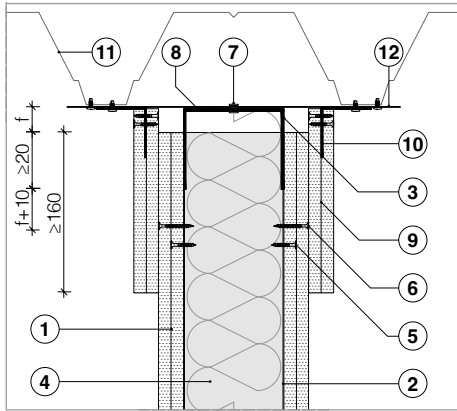

Fig. 6. Connecting a partition wall with trapezoidal sheet panels using plasterboard "curtains" – along the trapeze

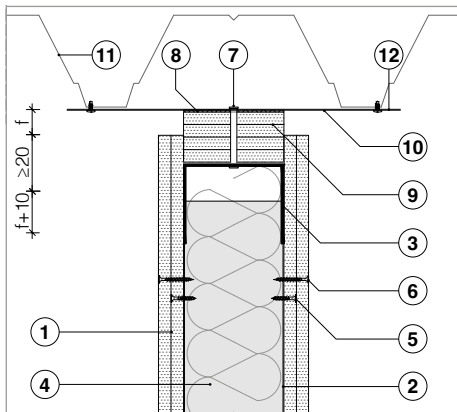

Fig. 7. Connecting a partition wall with trapezoidal sheet panels using plasterboard spacers – along the trapeze

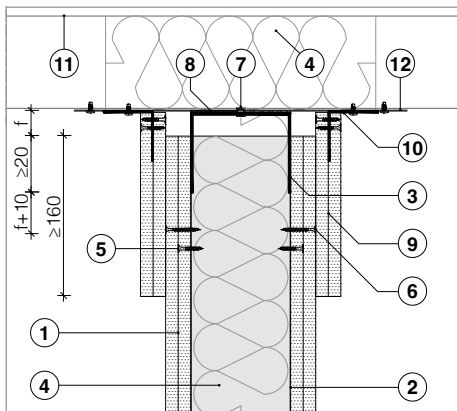
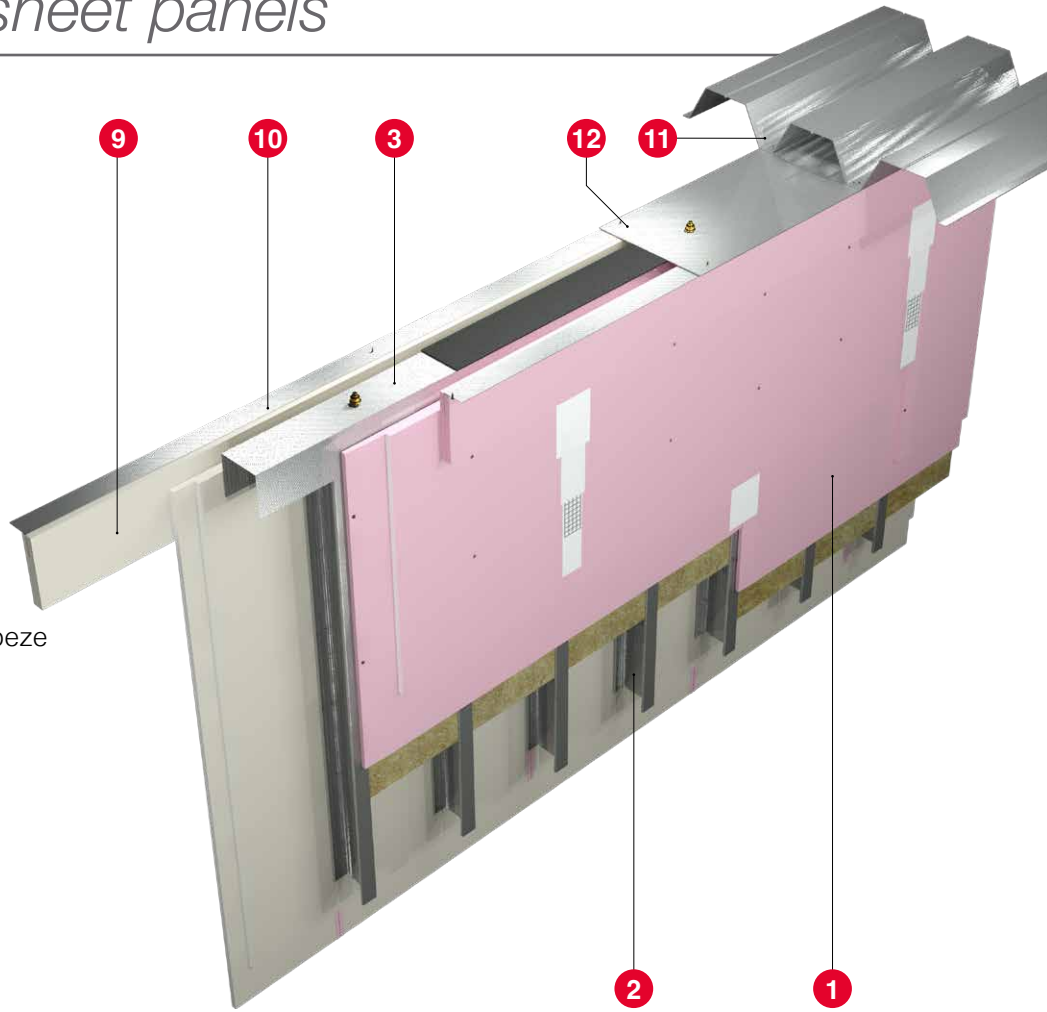

Fig. 8. Connecting a partition wall with trapezoidal sheet panels – diagonally across the trapeze (alternatively plasterboard spacers can be used – see Fig. 7)



### Construction elements:

1. NORGIPS plasterboard
2. NORGIPS CW profile
3. NORGIPS U special profile, min. 100 x 80 mm
4. Mineral wool
5. NORGIPS 3.5 x 25 mm tapping screw
6. NORGIPS 3.5 x 35 mm tapping screw
7. Mechanical fastener
8. Foam sealing tape
9. NORGIPS plasterboard strips
10. Steel angle section, min. 50 x 50 mm
11. Trapezoidal sheet panel
12. Steel sheet, thickness min. 1 mm

f – designed ceiling deflection

# UPPER JOINTS

## Connecting a NORGIPS partition wall with a combustible ceiling

Due to the requirement regarding protection of ceilings made of materials classified as combustible, one solution is to use an additional protective plasterboard lining (up to fire resistance class EI60).

This requirement can be met by applying the construction method shown in Fig. 7 or 8.

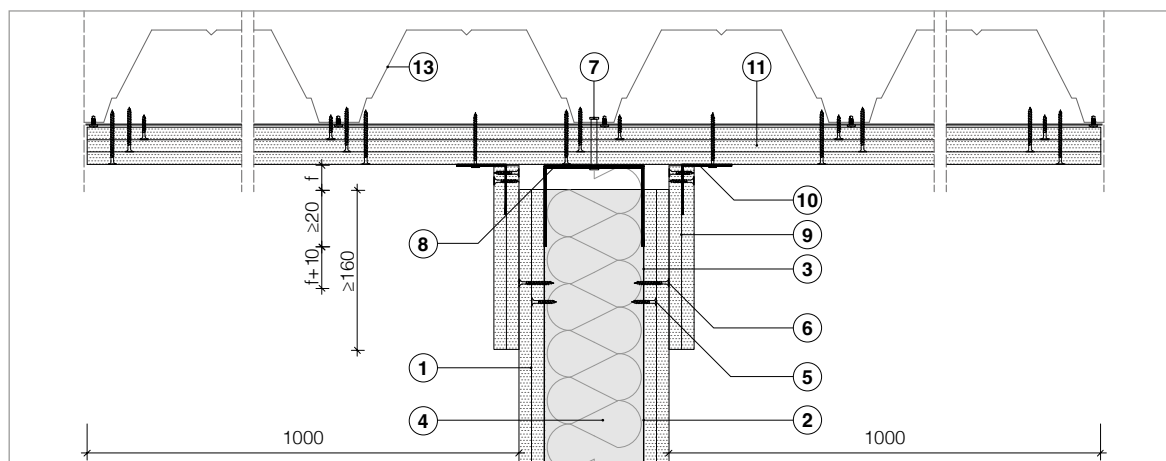

Fig. 9. Connecting a wall with a ceiling with combustible covering – the use of plasterboard lining

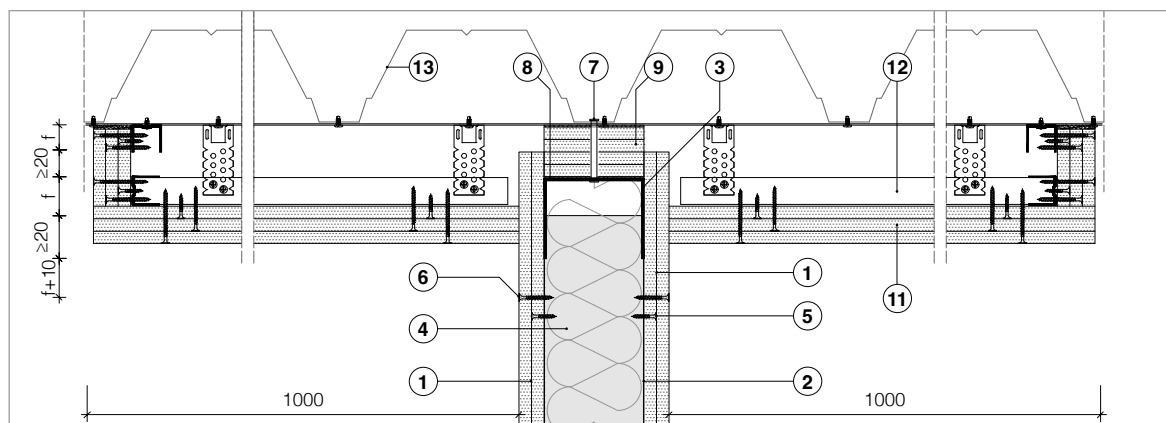

Fig.10. Connecting a wall with a ceiling with combustible covering – the use of suspended ceiling or lining

### Construction elements:

- |  |   |
|--|---|
| 1. NORGIPS plasterboard                        | 8. Foam sealing tape                                      |
| 2. NORGIPS CW profile                          | 9. NORGIPS plasterboard strips                            |
| 3. NORGIPS U special profile, min. 100 x 80 mm | 10. Steel angle section, min. 50 x 50 mm                  |
| 4. Mineral wool                                | 11. NORGIPS plasterboard type DF 3 x 12.5 mm or 2 x 15 mm |
| 5. NORGIPS 3.5 x 25 mm tapping screw           | 12. Lining or NORGIPS suspended ceiling                   |
| 6. NORGIPS 3.5 x 35 mm tapping screw           | 13. Ceiling made of combustible materials                 |
| 7. Mechanical fastener                         |   |

f – designed ceiling deflection

# UPPER JOINTS

## Connecting a NORGIPS partition wall with a ceiling

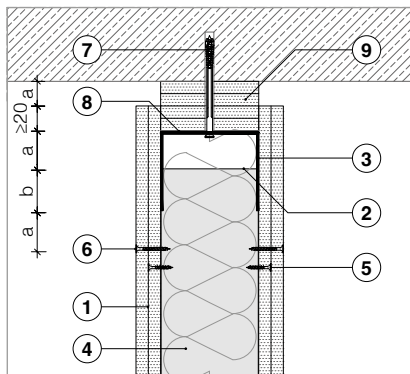

Fig. 11. Connecting a partition wall ( $h > 6.5$  m) – variant 1 (with plasterboard spacers)

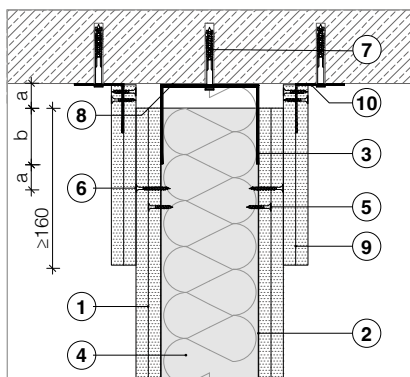

Fig. 12. Connecting a partition wall ( $h > 6.5$  m) – variant 2 (with plasterboard "curtains")

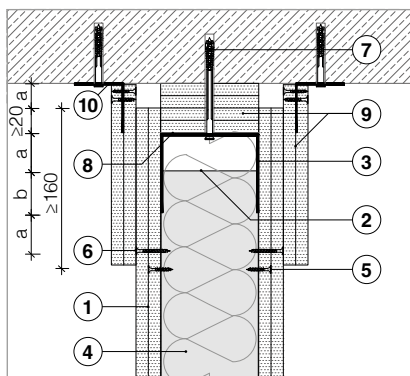
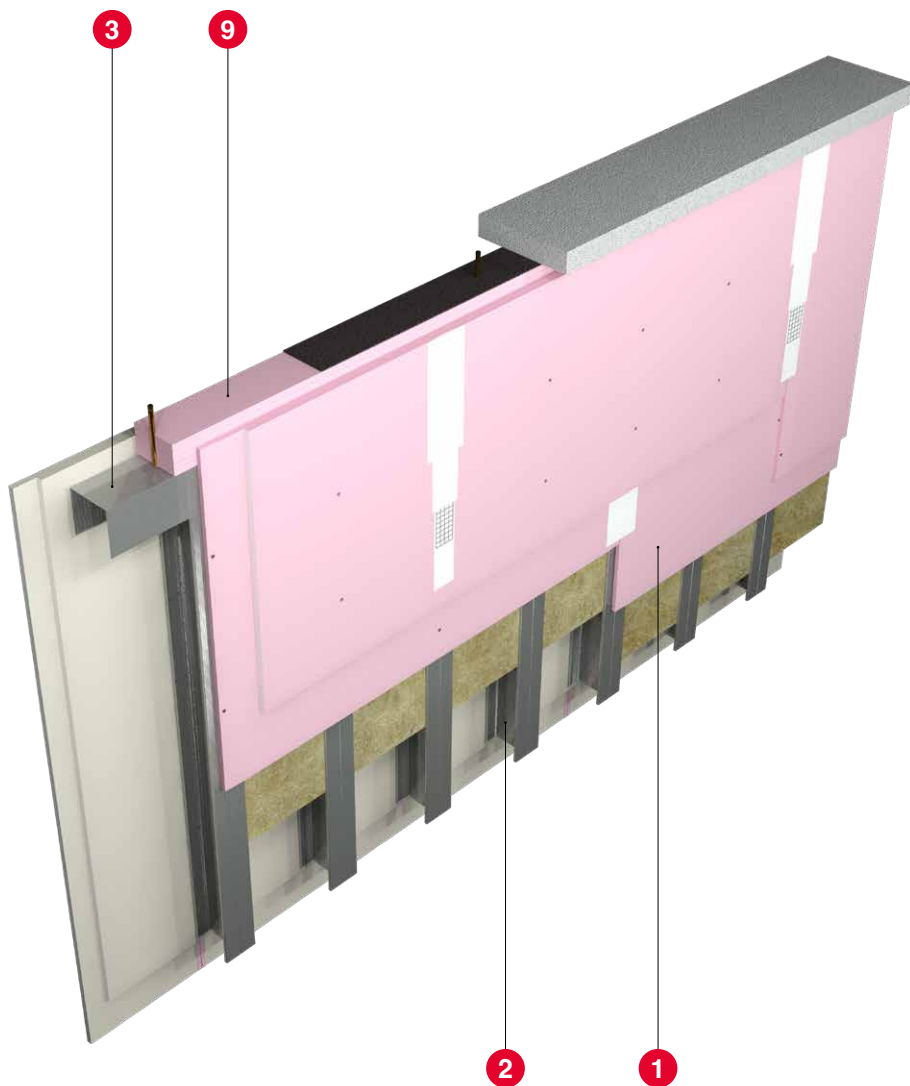

Fig. 13. Connecting a partition wall ( $h > 6.5$  m) – variant 3



### Construction elements:

1. NORGIPS plasterboard, type DF
2. Doubled NORGIPS CW profile
3. NORGIPS U special profile, min. 100 x 80 mm\*
4. Mineral wool
5. NORGIPS 3.5 x 25 mm tapping screw
6. NORGIPS 3.5 x 35 mm tapping screw
7. Expansion stud or dowel
8. Foam sealing tape
9. NORGIPS plasterboard strips, type DF
10. Steel angle section, min. 50 x 50 mm

a, b – shift coefficient depending on the ceiling deflection  
\* selection in line with the table at the end of the document

# LOWER JOINTS

## Connecting a partition wall with a floor

### Construction elements:

1. NORGIPS plasterboard
2. NORGIPS CW profile
3. NORGIPS UW profile
4. Mineral wool
5. NORGIPS 3.5 x 25 mm tapping screw
6. NORGIPS 3.5 x 35 mm tapping screw
7. Expansion stud or dowel
8. Foam sealing tape
9. NORGIPS gypsum joint filler
10. Dry screed floor panels
11. Dry screed floor expansion joint
12. Dry screed floor circumferential insulation
13. Mineral wool

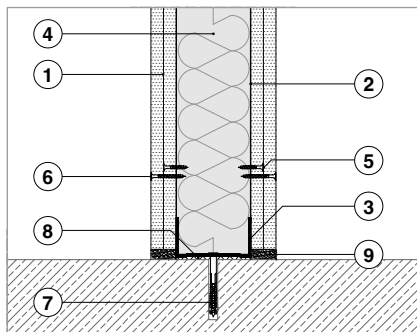

Fig. 14. Connecting a partition wall with concrete floor

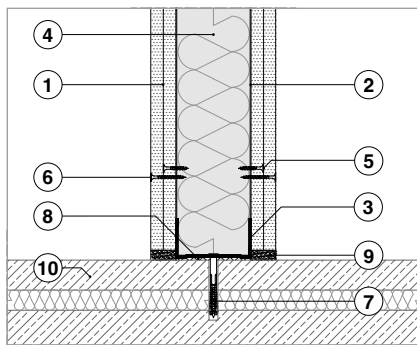
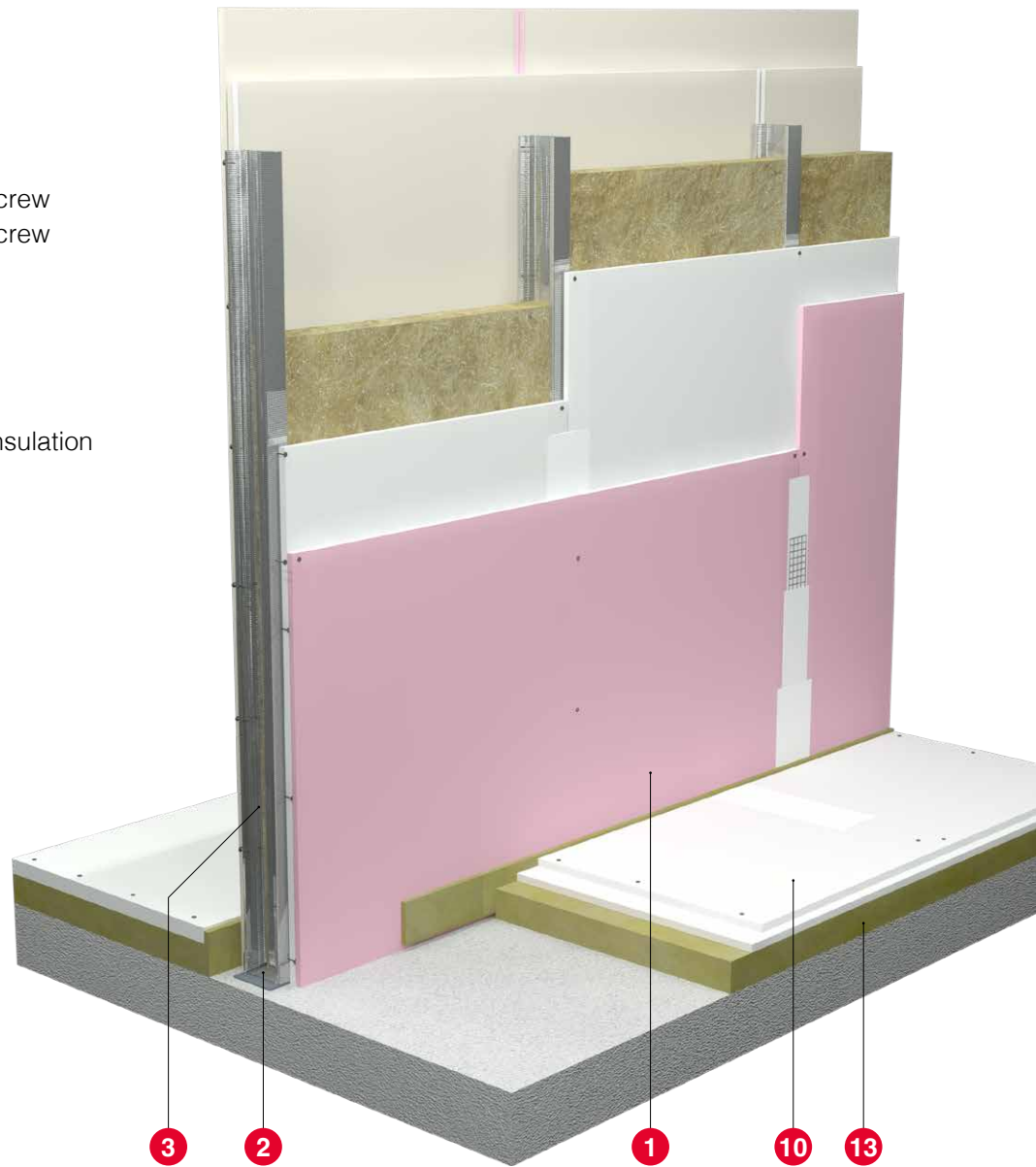

Fig. 15. Connecting a partition wall with dry screed floor – this solution is not recommended due to acoustic reasons

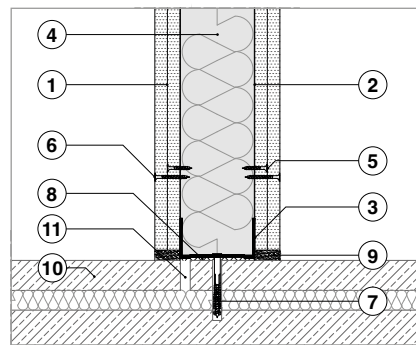

Fig. 16. Connecting a partition wall with dry screed floor with an acoustic gap

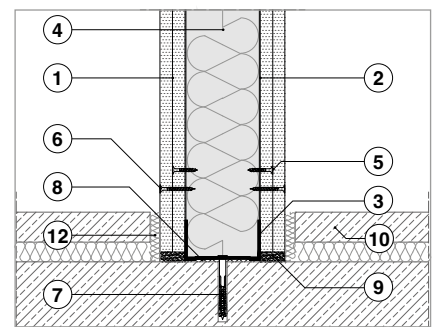

Fig. 17. Connecting a partition wall with concrete floor and dry screed panels with dry jointless floor against the wall

# JOINT DETAILS

## Type T joints: partition walls

### Construction elements:

1. NORGIPS plasterboard
2. NORGIPS CW profile
3. NORGIPS UW profile
4. Mineral wool
5. NORGIPS 3.5 x 25 mm tapping screw
6. NORGIPS 3.5 x 35 mm tapping screw
7. Fastener for empty spaces
8. Foam sealing tape
9. NORGIPS gypsum joint filler
10. Reinforcing tape

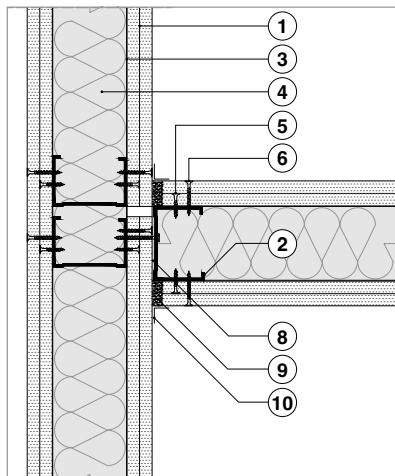
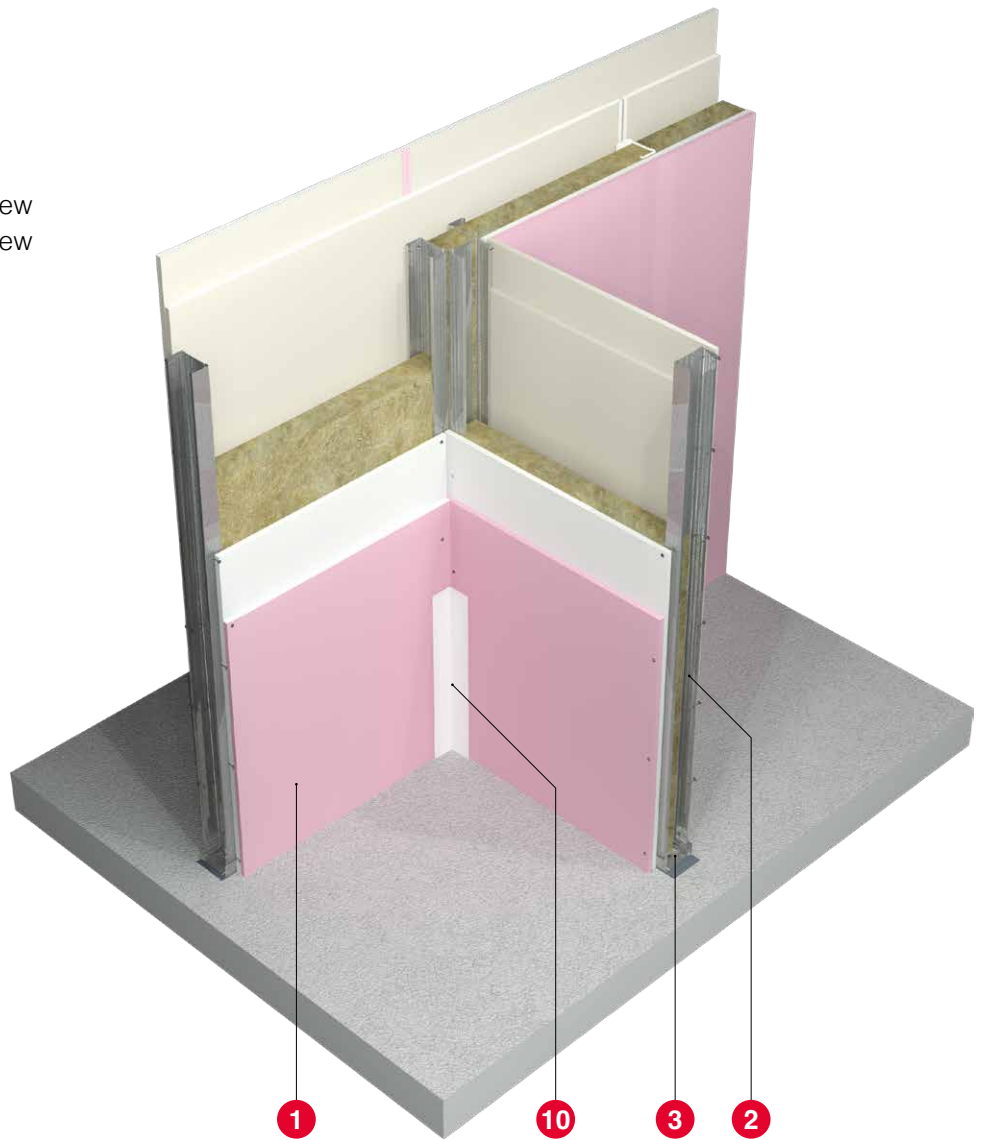

Fig. 18. Type T joint with acoustic gap

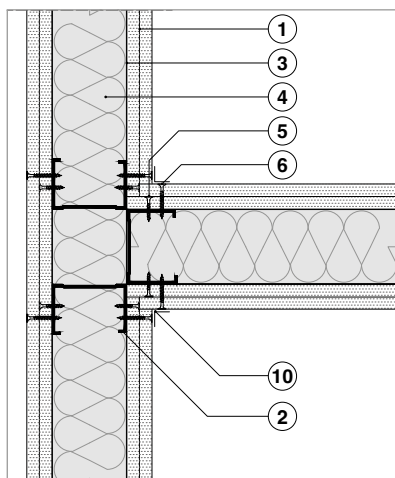

Fig. 19. Type T acoustic joint

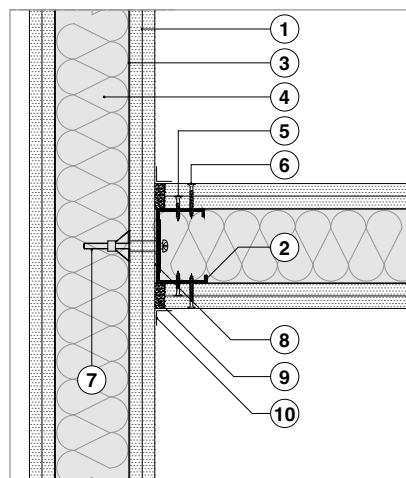
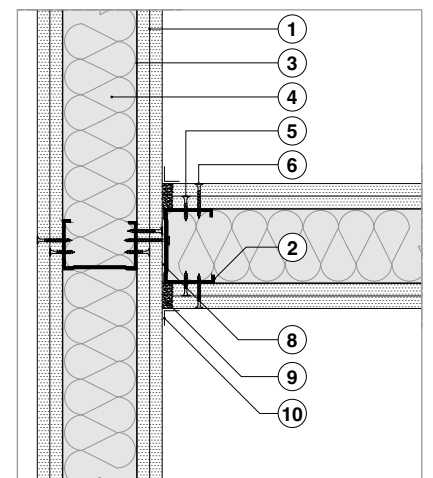

Fig. 20. Type T joint  
– plasterboard-wall connection



Rys. 21. Połączenie typu T  
– nie zalecane akustycznie

# JOINT DETAILS

## Type T joints: partition wall – massive wall

### Construction elements:

1. NORGIPS plasterboard
2. NORGIPS CW profile
3. NORGIPS UW profile
4. Mineral wool
5. NORGIPS 3.5 x 25 mm tapping screw
6. NORGIPS 3.5 x 35 mm tapping screw
7. NORGIPS 3.5 x 45 mm tapping screw
8. Foam sealing tape
9. NORGIPS gypsum joint filler
10. Reinforcing tape

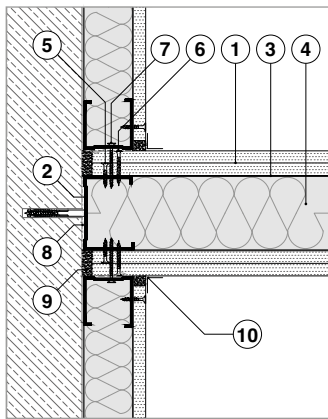
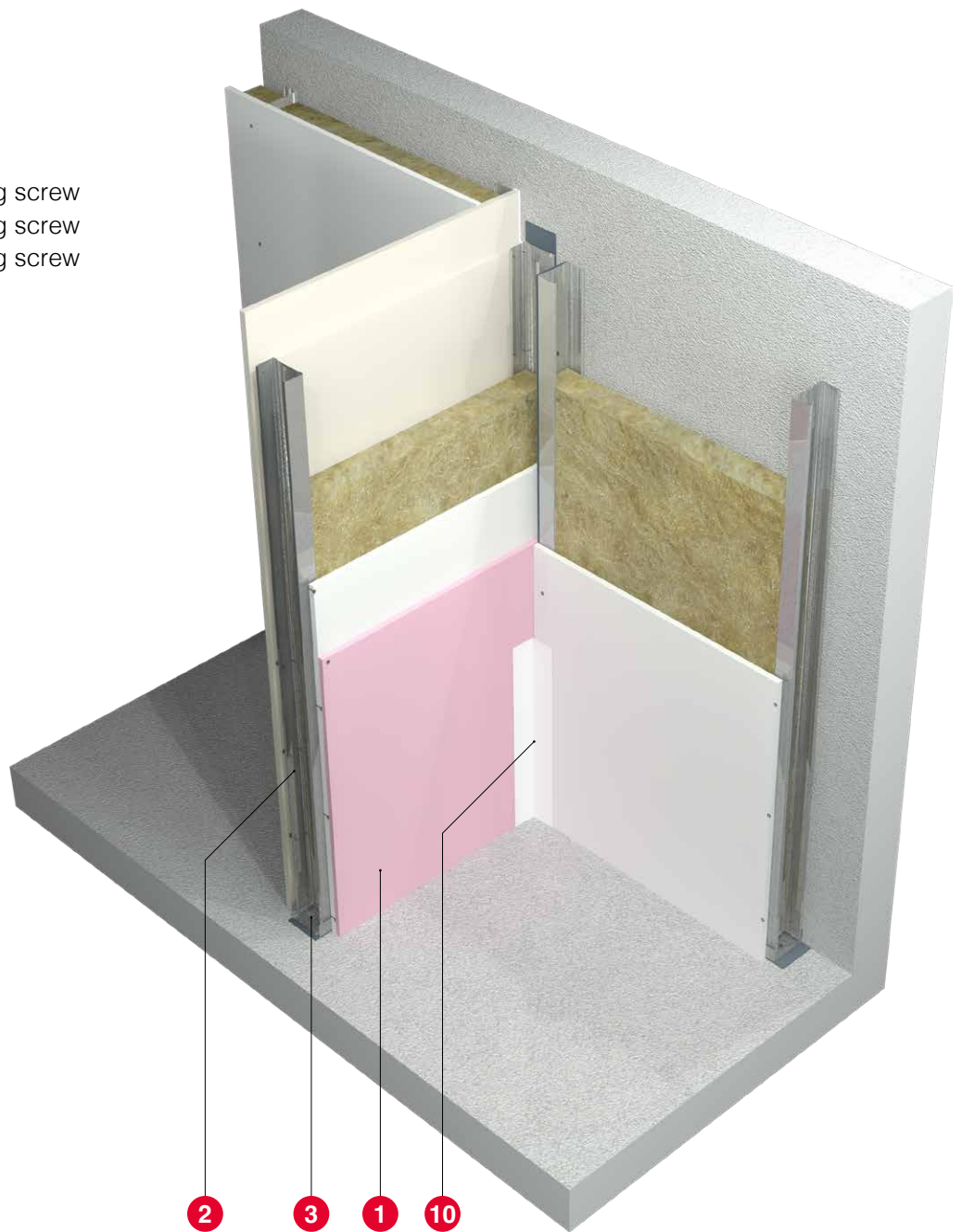

Fig. 22. Connecting a partition wall with a massive wall



# JOINT DETAILS

## Type L joints

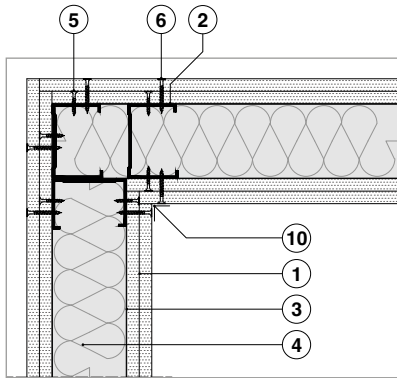

Fig. 23. Type L joint  
– variant 1

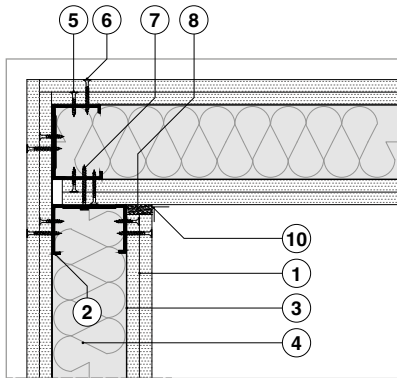

Fig. 24. Type L joint  
– variant 2

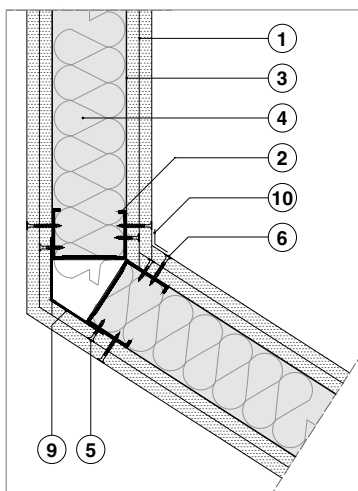
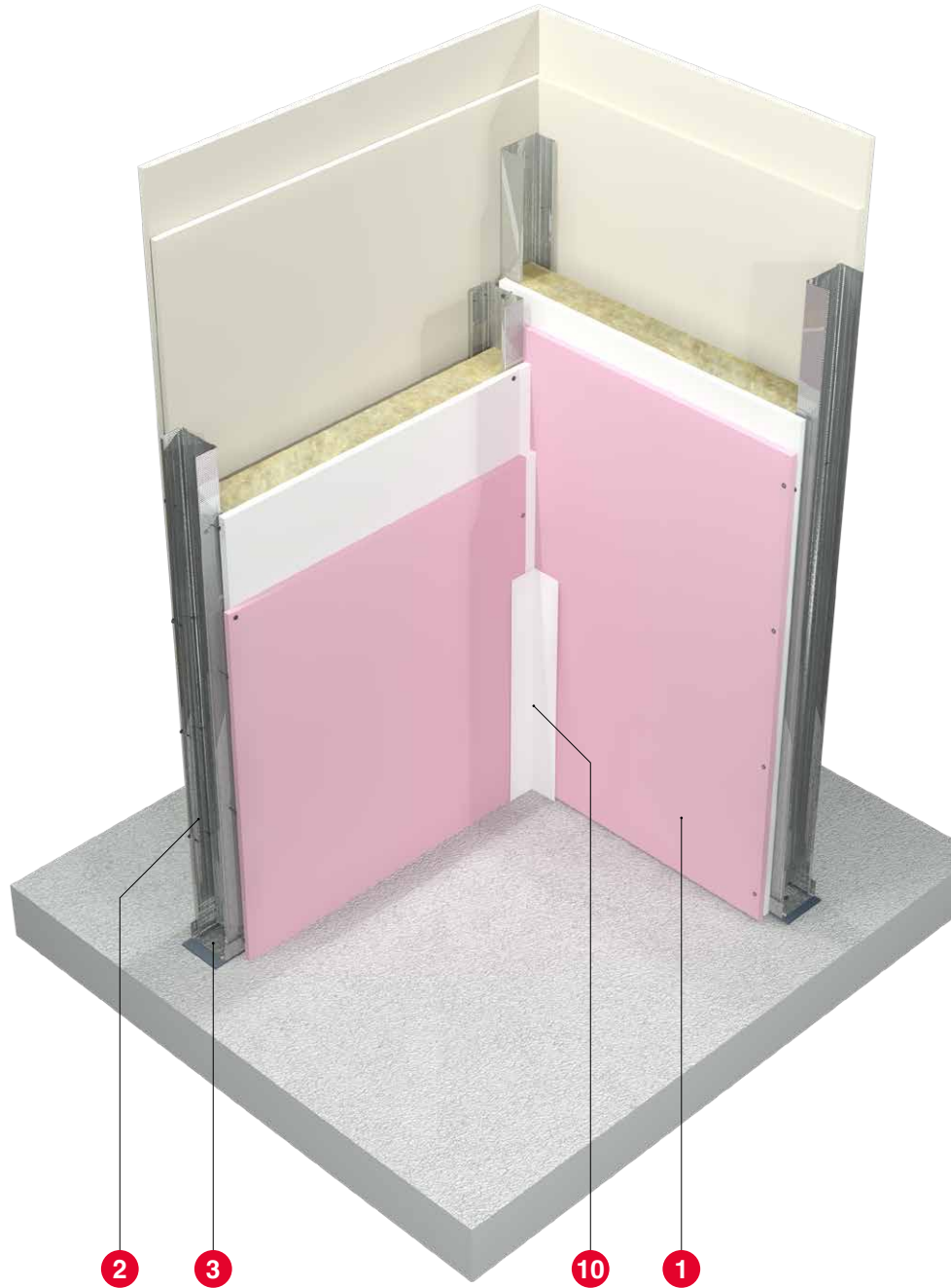

Fig. 25. Type L joint  
– obtuse angle



### Construction elements:

1. NORGIPS plasterboard
2. NORGIPS CW profile
3. NORGIPS UW profile
4. Mineral wool
5. NORGIPS 3.5 x 25 mm tapping screw
6. NORGIPS 3.5 x 35 mm tapping screw
7. NORGIPS 3.5 x 45 mm tapping screw
8. NORGIPS gypsum joint filler
9. NORGIPS Flex profile (optional)
10. Reinforcing tape

# JOINT DETAILS

## Expansion joints

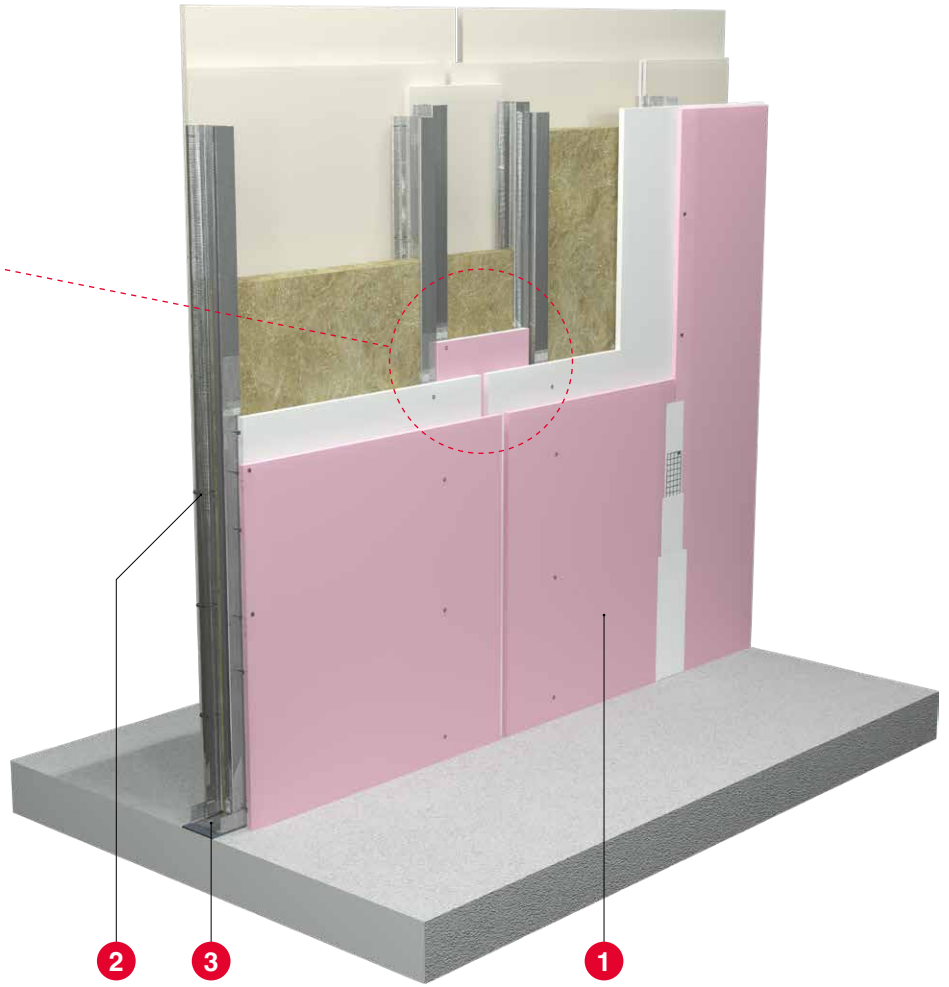

### Construction elements:

1. NORGIPS plasterboard
2. NORGIPS CW profile
3. NORGIPS UW profile
4. NORGIPS plasterboard strips
5. NORGIPS 3.5 x 25 mm tapping screw
6. NORGIPS 3.5 x 35 mm tapping screw
7. NORGIPS 3.5 x 9.5 mm tapping screw
8. NORGIPS tapping screw – length depending on the number of boards
9. Mineral wool
10. Aluminium semi-corner

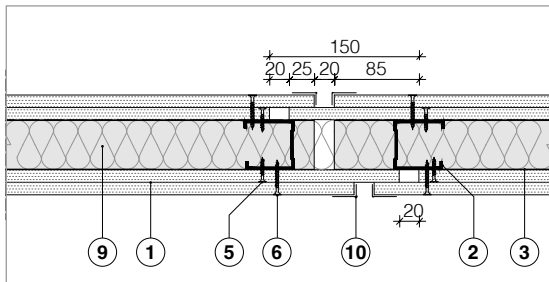

Fig. 26. Expansion joint – variant 1

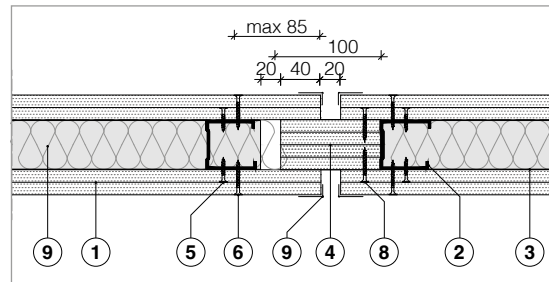

Fig. 27. Expansion joint – variant 2

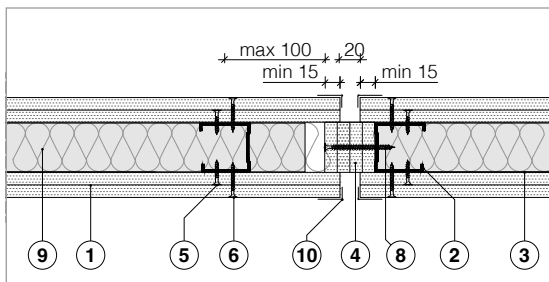

Fig. 28. Expansion joint – variant 3

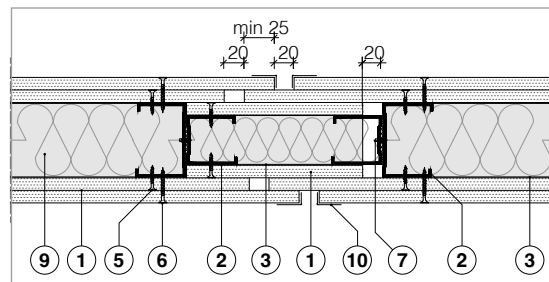
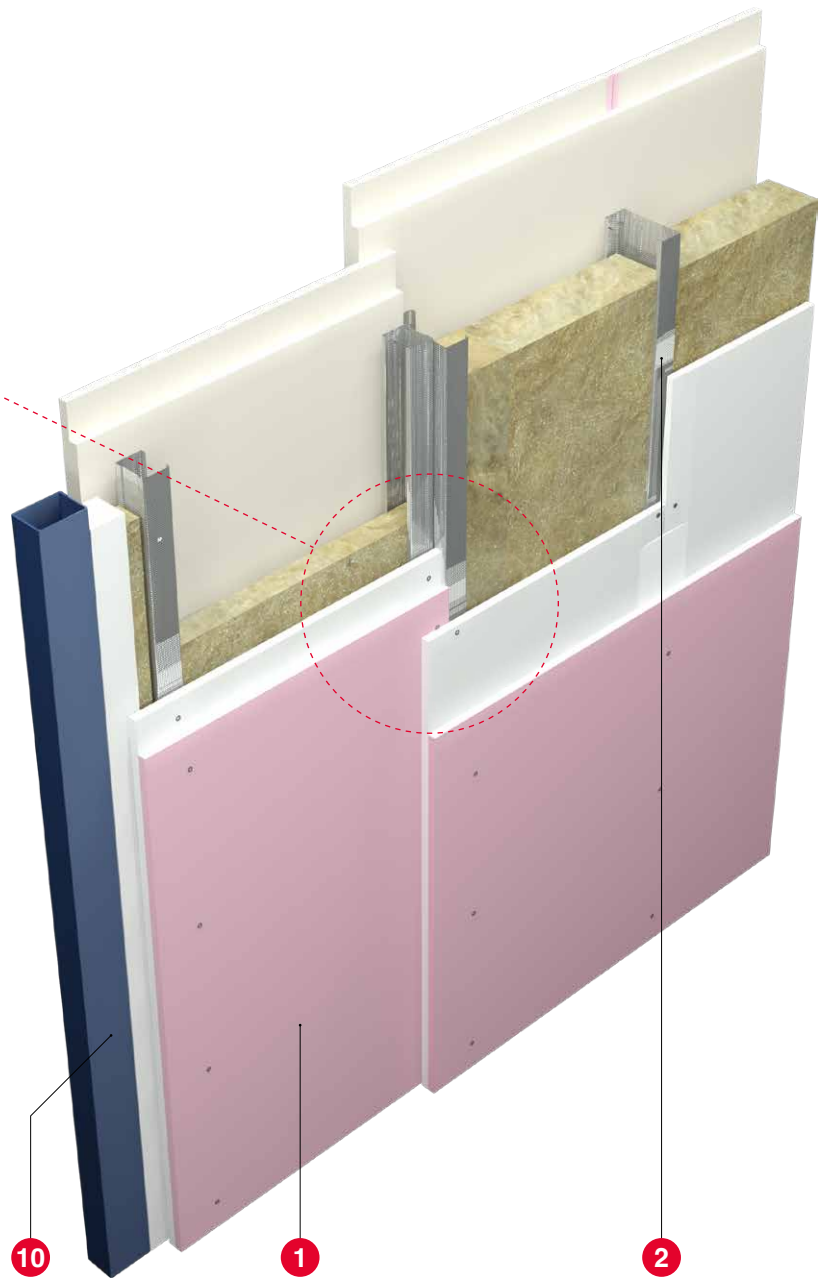
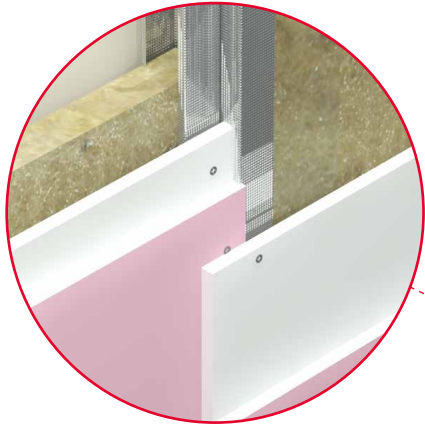

Fig. 29. Expansion joint – variant 4

# CONSTRUCTION DETAILS

## Wall width reduction



### Construction elements:

1. NORGIPS plasterboard
2. NORGIPS CW profile
3. NORGIPS UW profile
4. NORGIPS 3.5 x 25 mm tapping screw
5. NORGIPS 3.5 x 35 mm tapping screw
6. NORGIPS insulation tape
7. Mineral wool
8. NORGIPS tapping screw – length depending on the number of boards
9. Aluminium semi-corner
10. Building structure

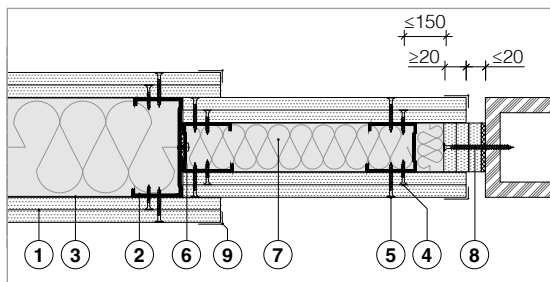

Fig. 30. Reduction joint connecting a partition wall with the wall structure

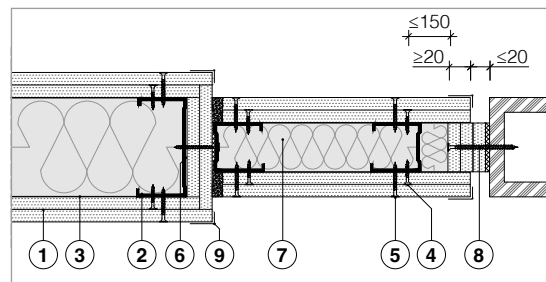

Fig. 31. Wall-to-wall reduction joint connecting to the wall structure

# CONSTRUCTION DETAILS

## Electric socket installation



### Construction elements:

1. NORGIPS plasterboard
2. Electrical box
3. Mineral wool
4. Compressed mineral wool
5. Electrical box enclosure made of NORGIPS plasterboards
6. NORGIPS 3.5 x 55 mm tapping screw (length depending on the number of boards to be installed)
7. Electrical box sealing with NORGIPS gypsum joint filler

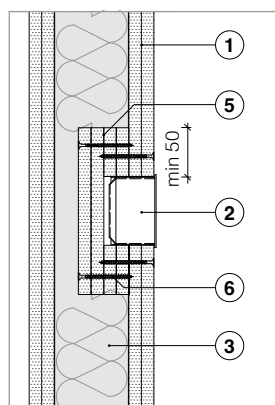

Fig. 32. Electric socket mounting – enclosure made of NORGIPS plasterboards

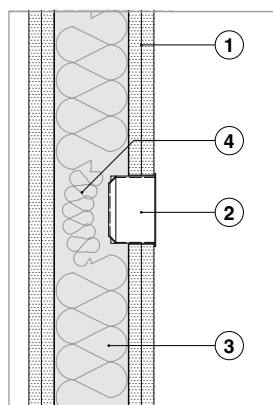

Fig. 33. Electric socket mounting – compressed mineral wool used

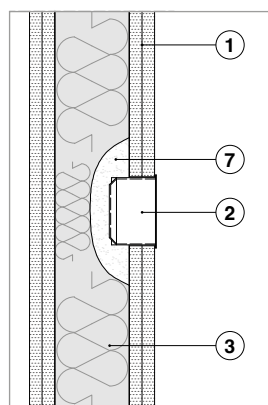

Fig. 34. Electric socket mounting – gypsum filler used

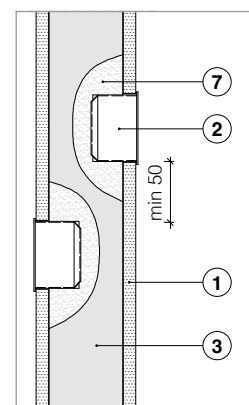

Fig. 35. Distances between opposite electric sockets

# CONSTRUCTION DETAILS

## Installation enclosure

### Construction elements:

1. NORGIPS plasterboard
2. NORGIPS UD30 profile
3. NORGIPS 3.5 x 25 mm tapping screw
4. NORGIPS joint filler
5. Expansion stud or dowel
6. NORGIPS partition wall
7. Installation piping

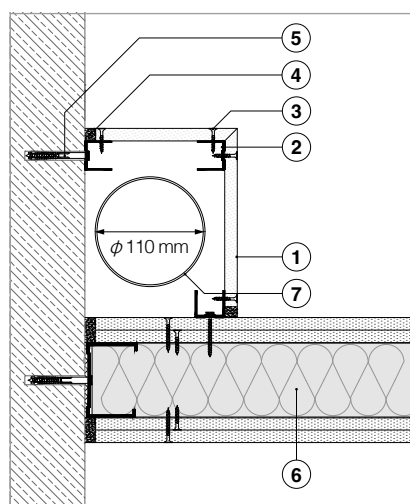
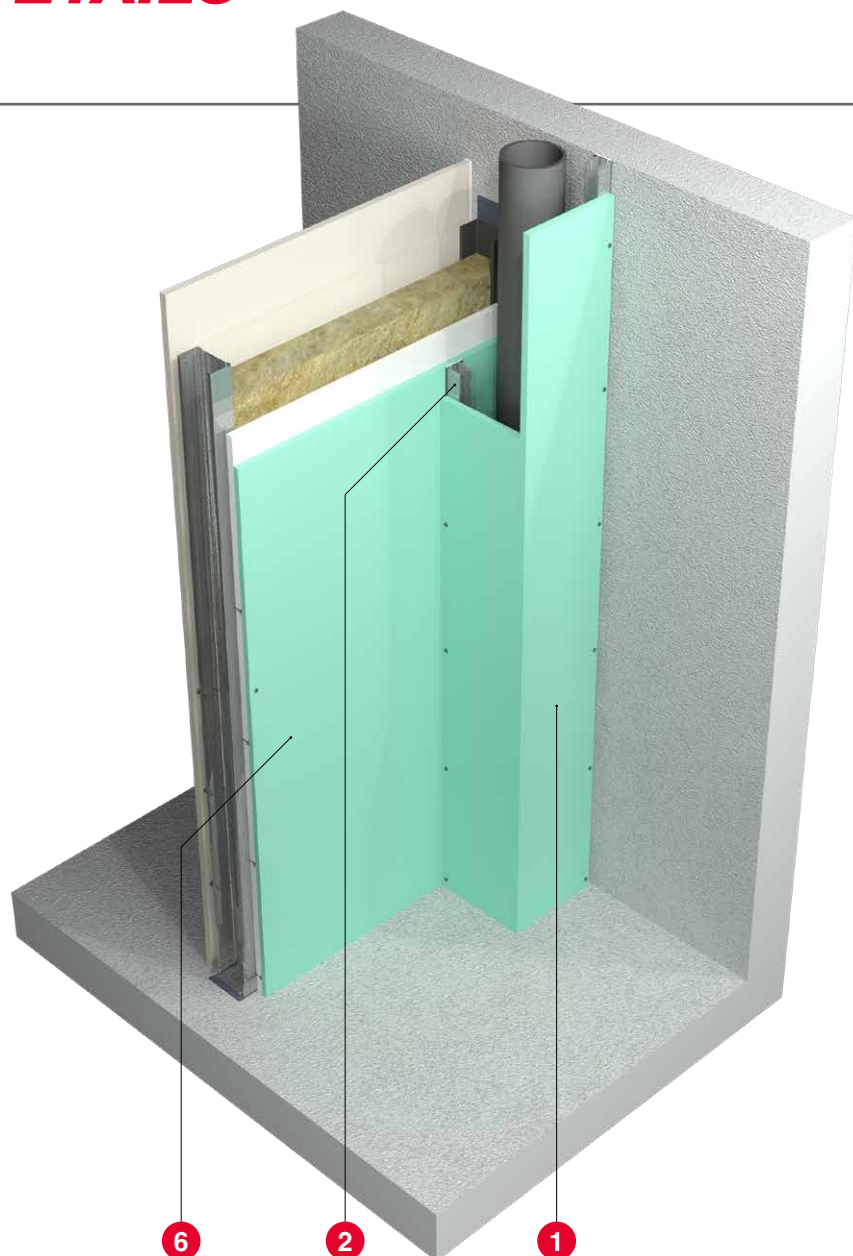

Fig. 36. Corner installation enclosure made of plasterboards

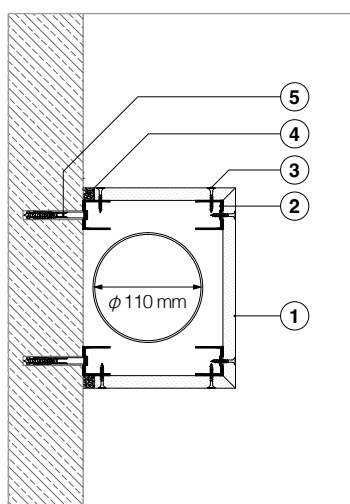

Fig. 36. Installation enclosure made of plasterboards

# SANITARY ROOMS

## Sealing

### Sealing elements:

1. Impregnated boards, type H2, DFH2 or DFH2IR
2. Waterproofing, e.g. liquid foil
3. Sealing tape
4. Tile adhesive
5. Ceramic tiles

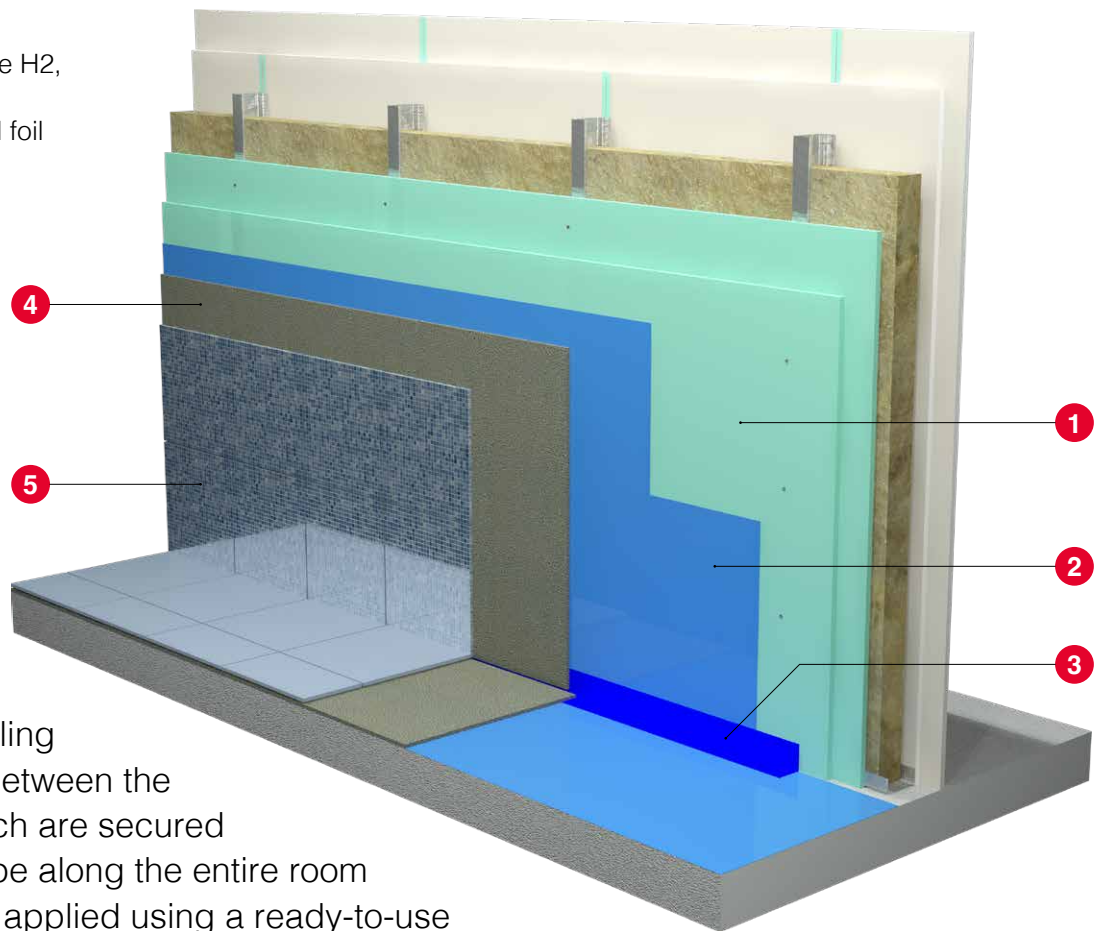

One of the most important stages of insulation mounting process is correct sealing of the contact points between the floor and the wall, which are secured by gluing a sealing tape along the entire room perimeter. The tape is applied using a ready-to-use liquid foil product.

A waterproofing solution should especially be applied in areas exposed to splashing, located directly in the vicinity of the sanitary amenities, i.e.:

- bath tubs;
- showers;
- washbasins;
- bidet;

and on the bathroom floor.



Fig. 37. Wall areas particularly exposed to water splashes in a bathroom (marked grey)

# SANITARY ROOMS

## Fastening bathroom fittings on partition walls

### Fasteners:

1. CW profile
2. OSB board or wooden plank (thickness min. 1 cm)
3. Sanitary installations

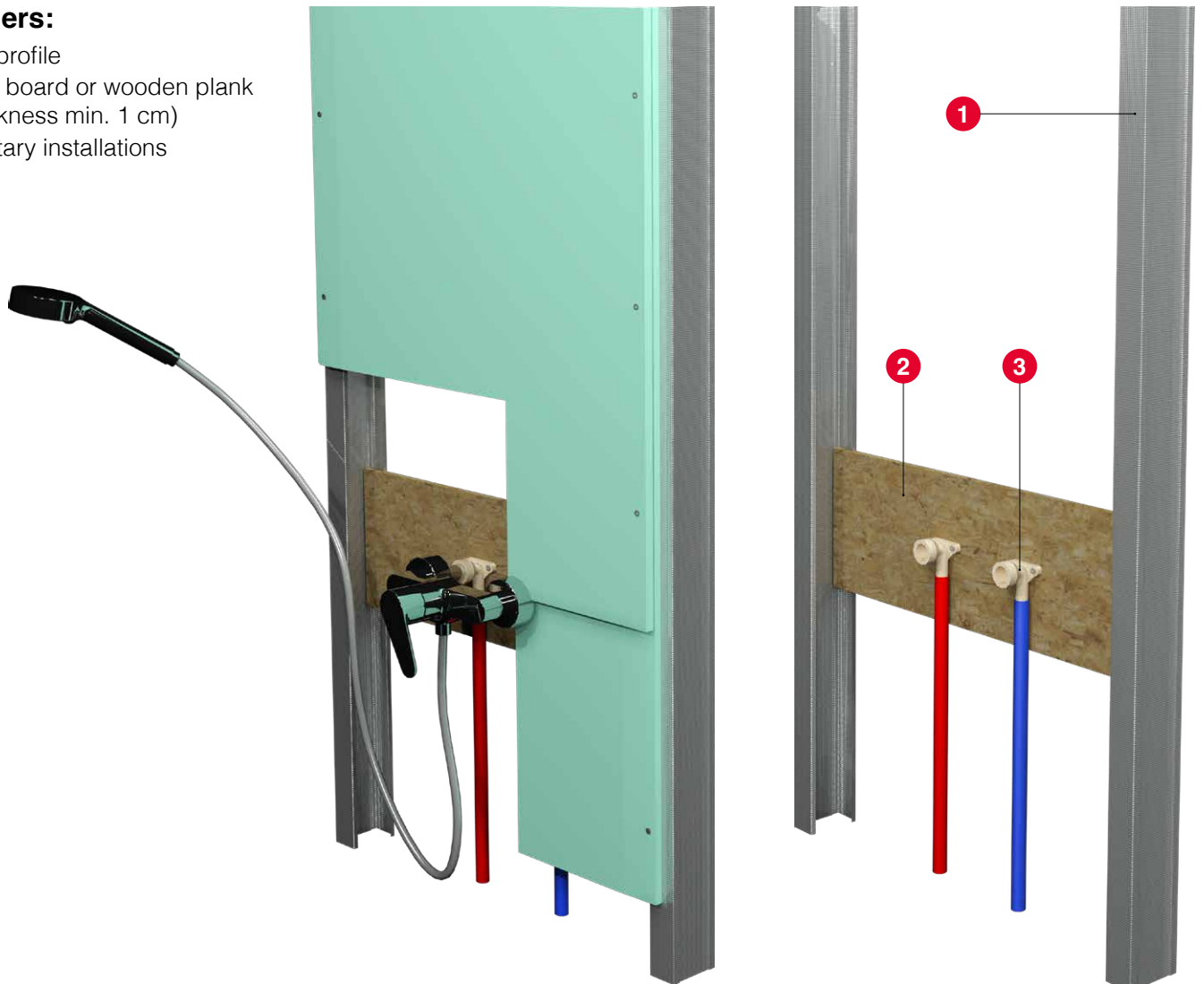

An OSB board or plank must be attached to CW profiles facing one another. If necessary, bend the CW profile edges.

Installations are mounted to an OSB board/plank in a manner described above.

Note that installation penetrations through plasterboards should be adequately insulated against water. Before applying an insulating agent, the plasterboard core should be primed.



# SANITARY ROOMS

## Flush-mounted frame installation

Sanitary flush-mounted frame in a partition wall

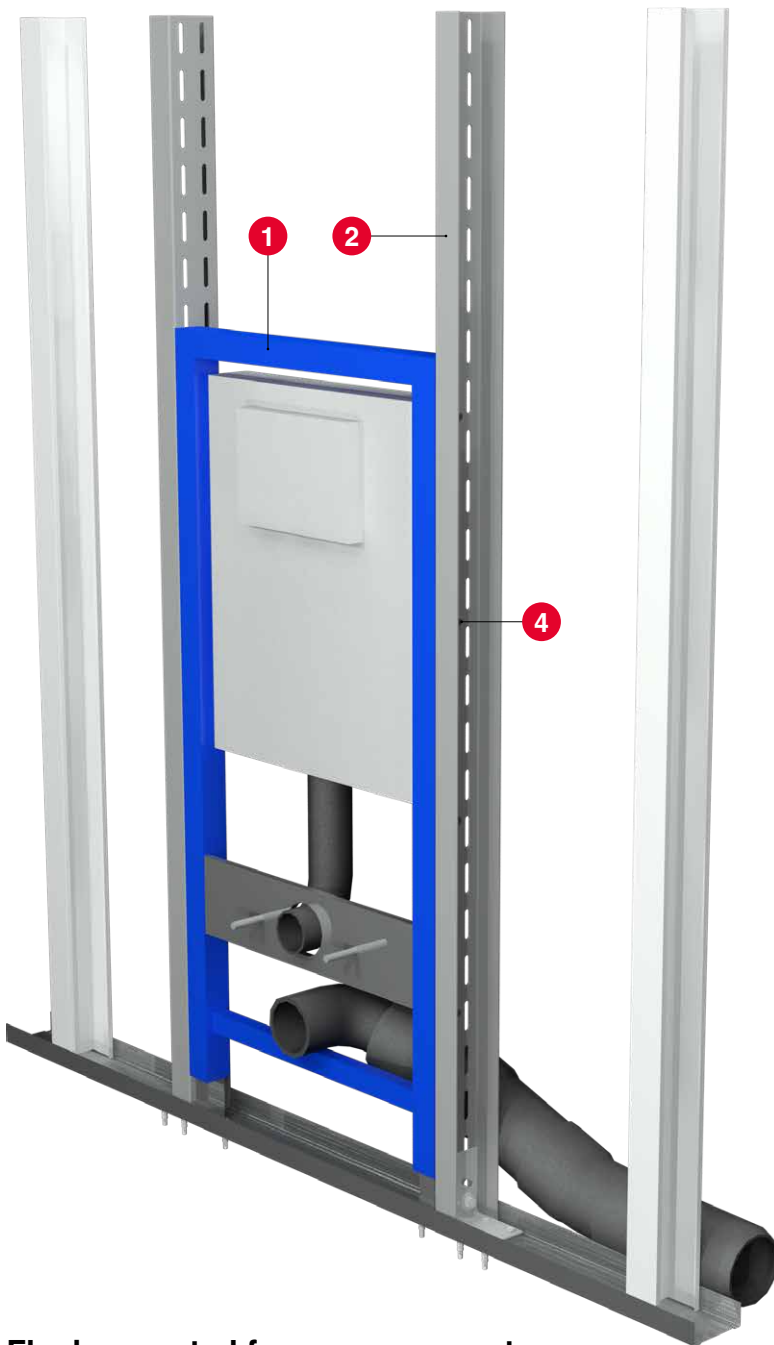

Sanitary flush-mounted frame installation

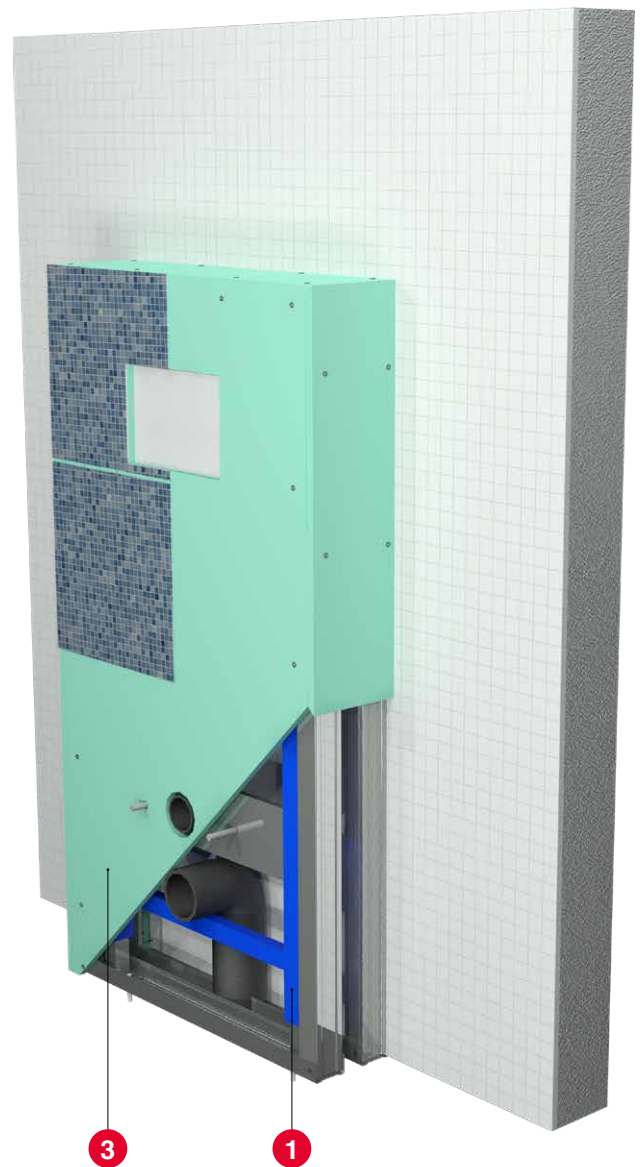

### Flush-mounted frame components:

1. Installation flush-mounted frame
2. UA profile
3. Plasterboard enclosure, type H2
4. Mechanical fastener

Flush-mounted systems for fittings (sanitary flush-mounted frames) must be attached to wall structures using the methods outlined above. In NORGIPS walls, flush-mounted frames are installed on the floor and UA vertical profiles, unless the manufacturer of the flush frames provides for mounting them to CW profiles.

# DOOR OPENINGS

## CW door frame profiles

In case:

- the door opening width is up to 90 cm;
- the partition wall height is up to 2.6 m;
- the door leaf weight does not exceed 25 kg

door frame profiles made of CW profiles are allowed.

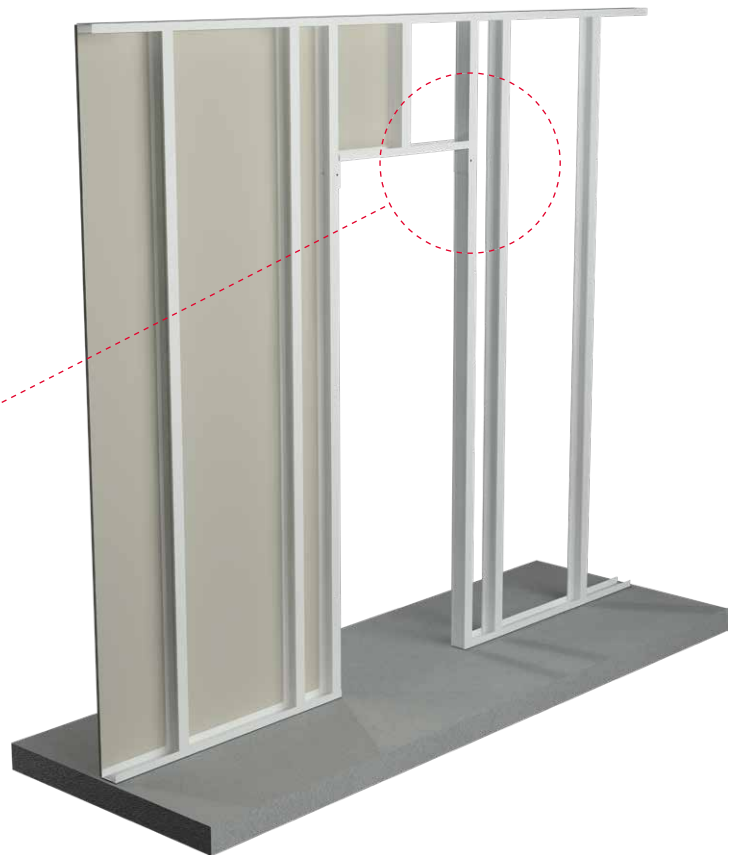
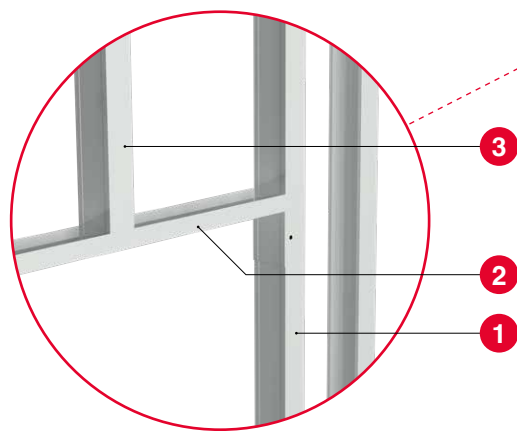

### Construction elements:

1. CW profile
2. UW profile
3. Crosspiece made of a CW profile\*



\* In case one crosspiece is installed, the whole plasterboard must be used on one side of the opening. Otherwise, two crosspieces must be provided.

# DOOR OPENINGS

## UA door frame profiles

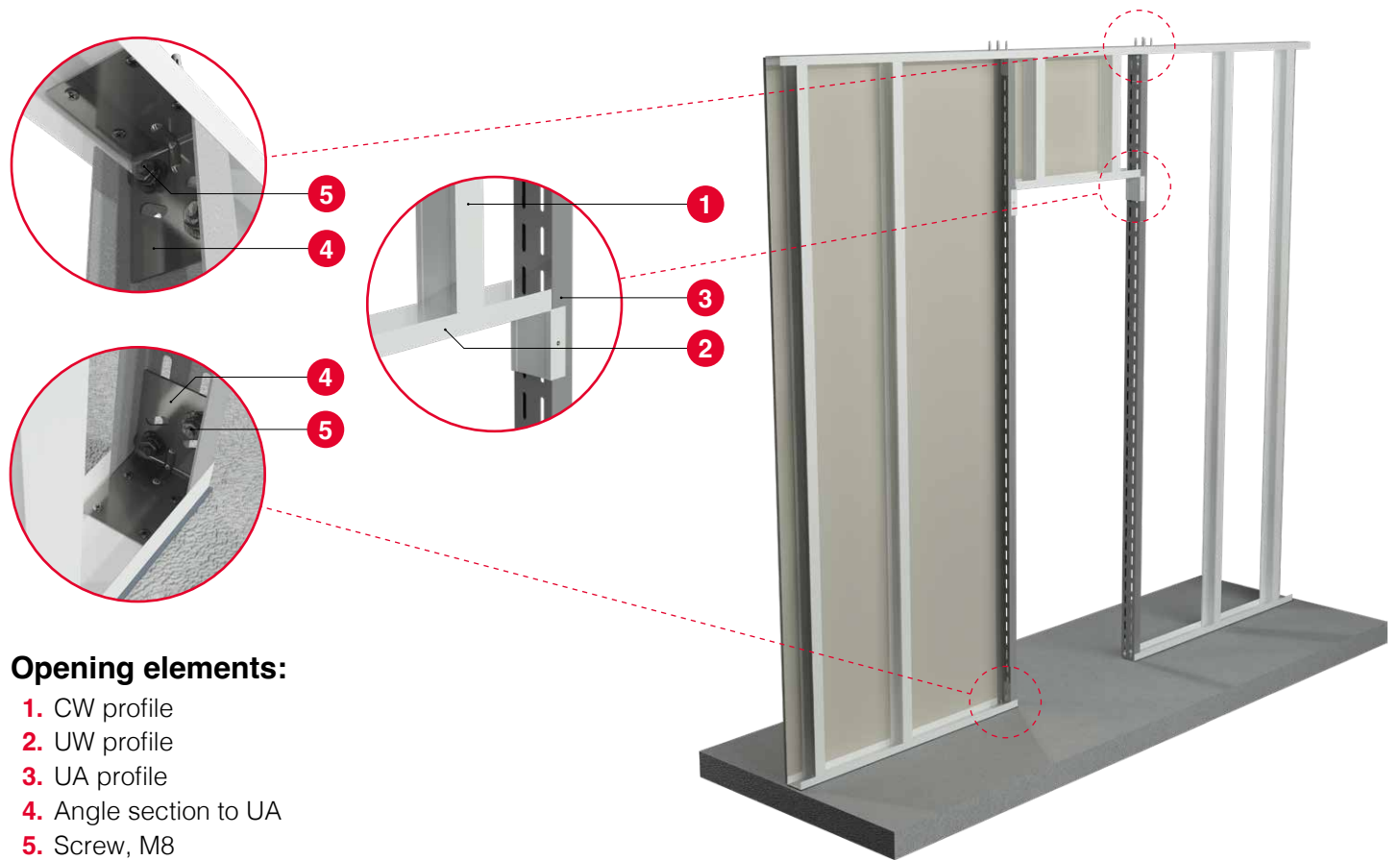

### Opening elements:

1. CW profile
2. UW profile
3. UA profile
4. Angle section to UA
5. Screw, M8

The door opening with the use of UA profiles is made when:

- the width of the door opening is 90 -120 cm
- wall height is in the range of 2,6 - 6,5 m
- door leaf weight does not exceed the value given in the table

Door opening width	UA50	UA75	UA100
up to 100 cm	50 kg	75 kg	100 kg
up to 120 cm	40 kg	60 kg	80 kg



# DOOR OPENINGS

## Door frame profiles – UA, opening width 120-150 cm

Door openings with the of 120-150 cm can be made in line with the following drawings:

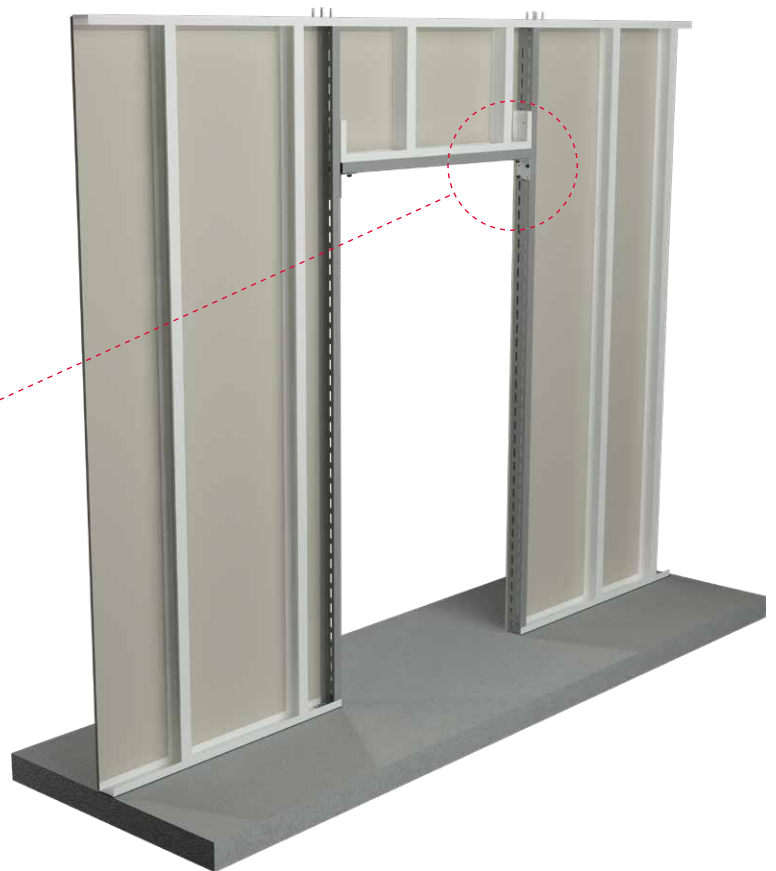

### Opening elements:

1. CW profile
2. UW profile
3. UA profile
4. Angle section to UA
5. Screw, M8

Maximum load on the UA profile with the door leaf:

Door opening width	UA50	UA75	UA100
120 - 150 cm	35 kg	50 kg	65 kg

An independent structure made of closed profiles should be made when:

- door openings are wider than 150 cm,
- the height of the wall is higher than 6.5 m
- the door leaf is heavier than the assumptions for UA profiles.

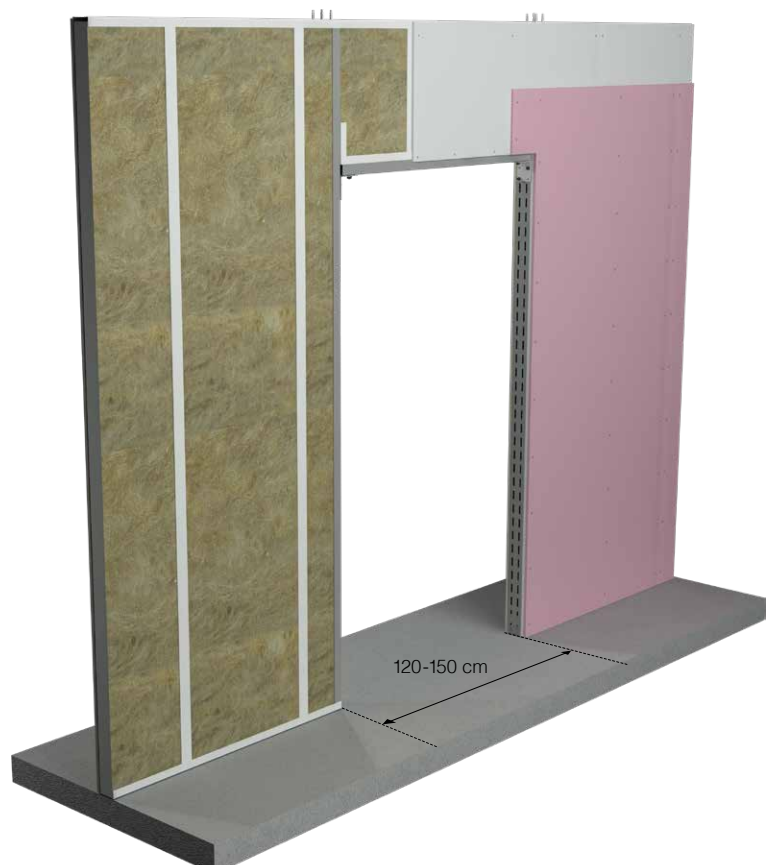

# SKYLIGHTS

## Construction elements:

1. CW profile
2. UW profile

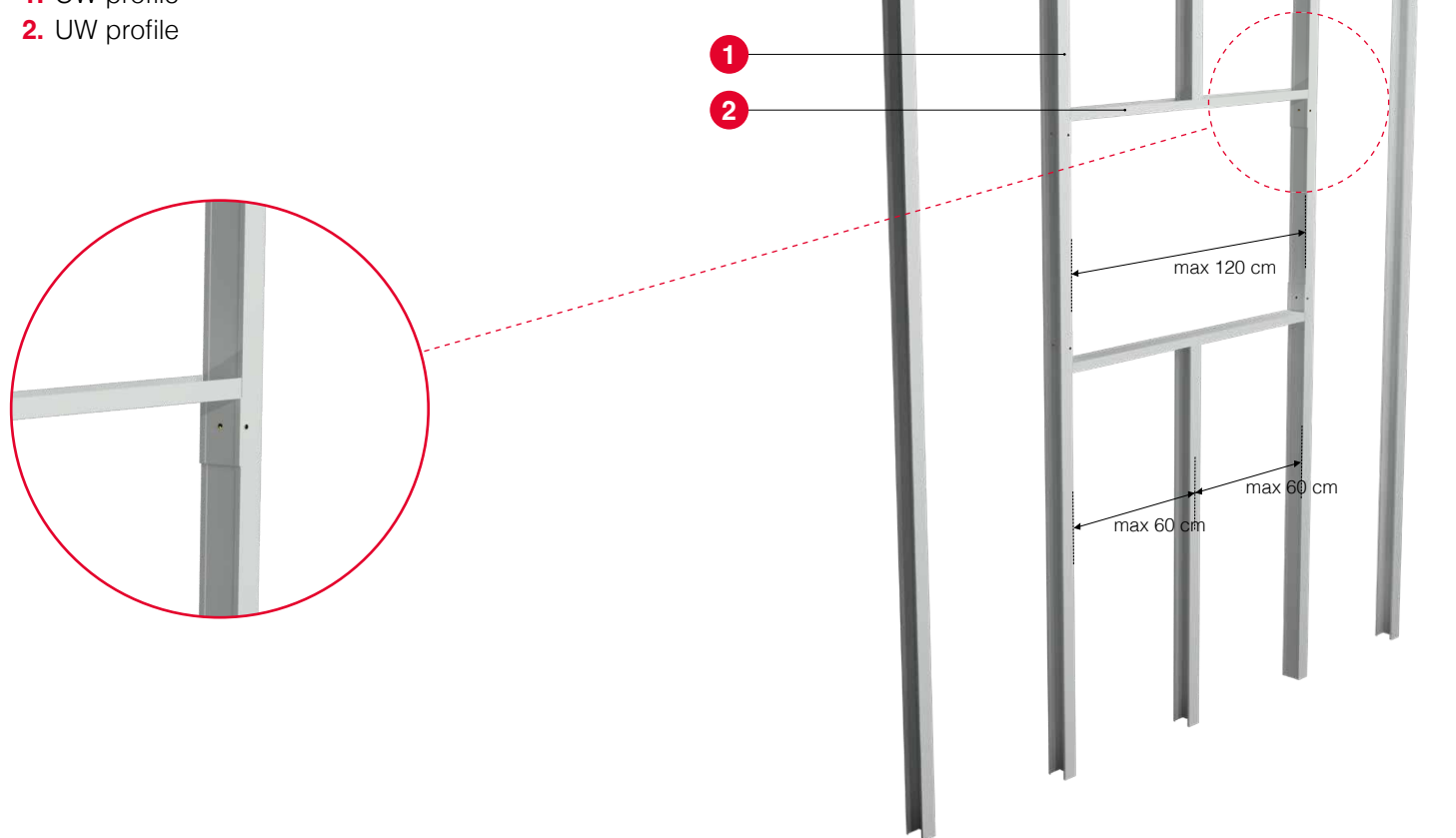

Skylight openings can be made in walls.

The maximum height of a wall in which a skylight opening can be made is 650 cm.

If the opening width does not exceed 120 cm, vertical profiles must be made of CW, and the horizontal ones of UW.

In case the width ranges from 120 cm to 240 cm, vertical and horizontal profiles creating the opening must be made of UA door frame profiles.

For openings larger than 240 cm made in walls whose height exceeds 650 cm or in case window joinery elements are installed in the openings, an independent substructure must be designed.



# SKYLIGHTS

## Construction elements:

1. CW profile
2. UW profile
3. UA profile
4. Angle section to UA
5. Screw, M8

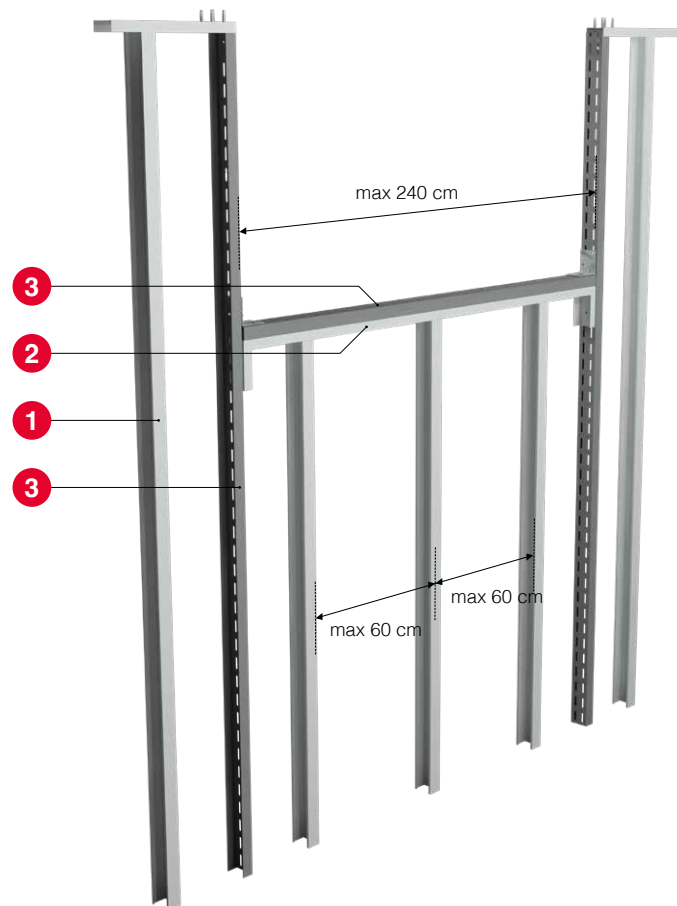
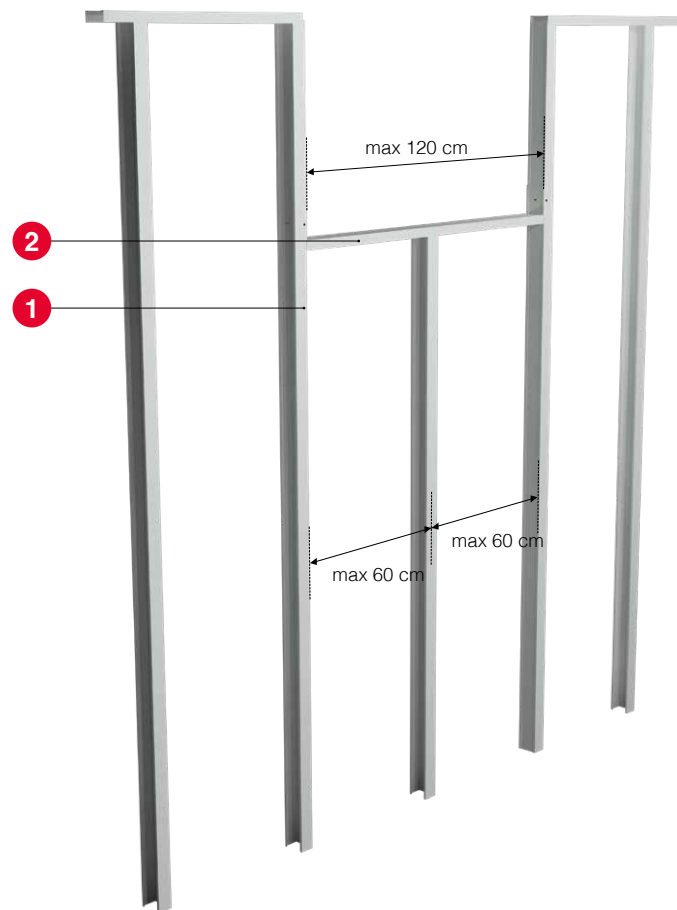
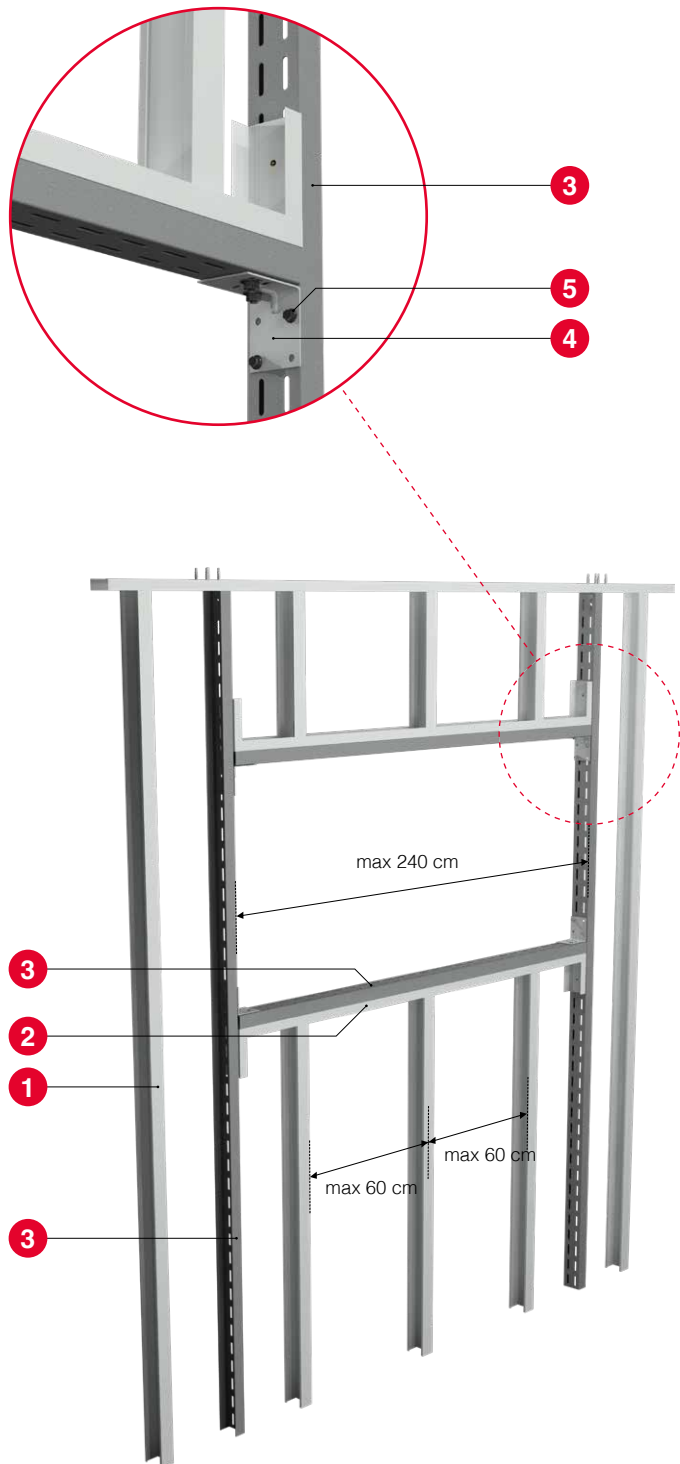

# PARTITION WALL CONSTRUCTION PROCEDURE

## Assembly stages

### STAGE I – installing horizontal profiles (UW) and vertical posts (CW)

1. Mark out the partition wall position in a room using e.g. a laser gauge by tracing the line of the perimeter profiles on the floor, walls and ceiling.
2. Apply a acoustic tape to the profiles coming in contact with the ceiling or wall, which will enhance the sound insulation of the partition wall.
3. Mount UW horizontal profiles to the ceiling and floor substrate, and fix CW vertical profiles to the wall.
4. Measure and place the remaining wall CW profiles so that they are spaced in line with the NORGIPS Solution (600, 400, 300 mm).

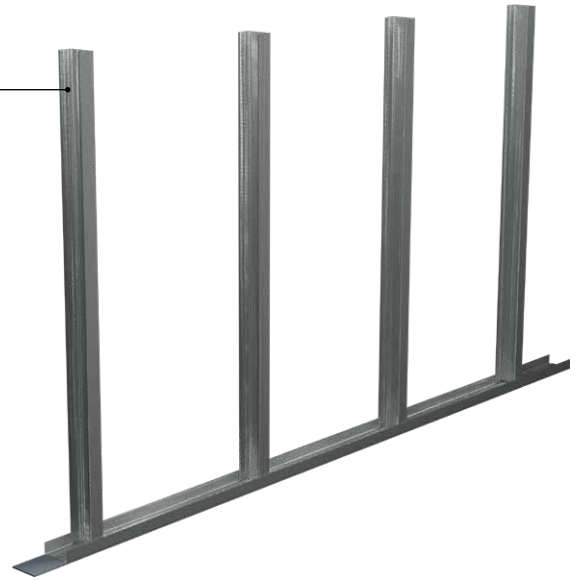

### STAGE II – installing the first NORGIPS sheeting layer

1. Glue the tape to massive wall sliding joints.
2. Attach the first layer of boards to the CW profile structure using 3,5x25 mm tapping screws spaced every 75 cm.



### STAGE III – installing wall insulation

1. Remove mineral wool from its packaging and spread on the substrate to let it expand.
2. Place the mineral wool between CW profiles.



# PARTITION WALL CONSTRUCTION PROCEDURE

## Installation process stages

### STAGE IV – installing other NORGIPS sheeting layers

1. Attach, from the other side of the wall, the first layer of boards to the CW profile structure using 3,5x25 mm tapping screws spaced every 75 cm.
2. Fill the joints between the first layer of boards with a joint filler.
3. Next, attach the second board layer on both sides, using 3,5x35 mm tapping screws spaced every 25 cm.

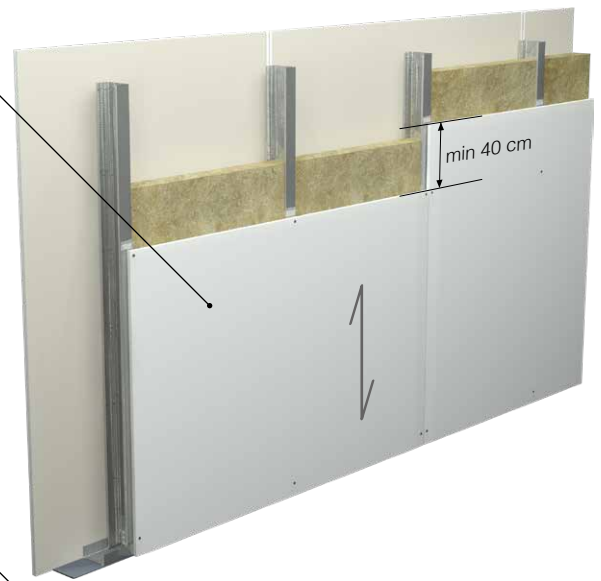
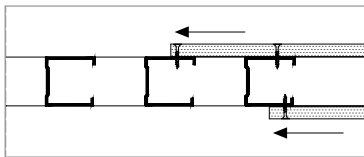

#### NOTE!

- Successive board layers should be fixed alternately, ensuring a shift with one profile;
- board joints must not cross;
- the distance between shorter board edges should be at least 40 cm.

### STAGE V – final pointing and filling

1. Fill the second layer of boards with a joint filler and pointing tape.
2. Fill the joints and screws with a finishing joint filler. More information on joint filling is provided in section “JOINT FILLING LEVELS”.
3. Buff all rough surfaces using a mechanical or manual polishing method.
4. After drying, the partition wall is ready for painting.



# **PARTITION WALL CONSTRUCTION PROCEDURE**

## *Horizontal sheeting*

---

The drywall technology also allows for creating partition walls with plasterboards fixed in a horizontal arrangement.

Here, the main difference in comparison with the layouts shown in pages 27-28 is the attached board orientation.

However, the general principles of partition wall construction described earlier must remain the same, i.e:

- wall profile installation;
- screw spacing in plasterboards;
- distances between plasterboard edges;
- alternate fixing of subsequent plasterboard layers;
- applying a joint filler to the wall.

In this case the partition wall arrangement is as follows:

### **FIRST SHEETING LAYER**



### **SECOND SHEETING LAYER**



↔ – sheeting direction

# JOINT FILLING LEVELS

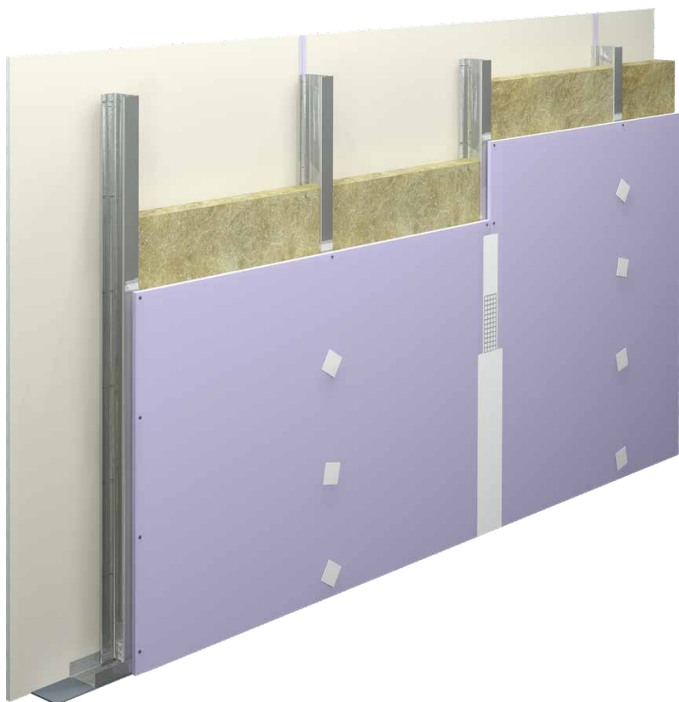

**Q1** Filling screw openings and plasterboard joints with reinforcing tape.

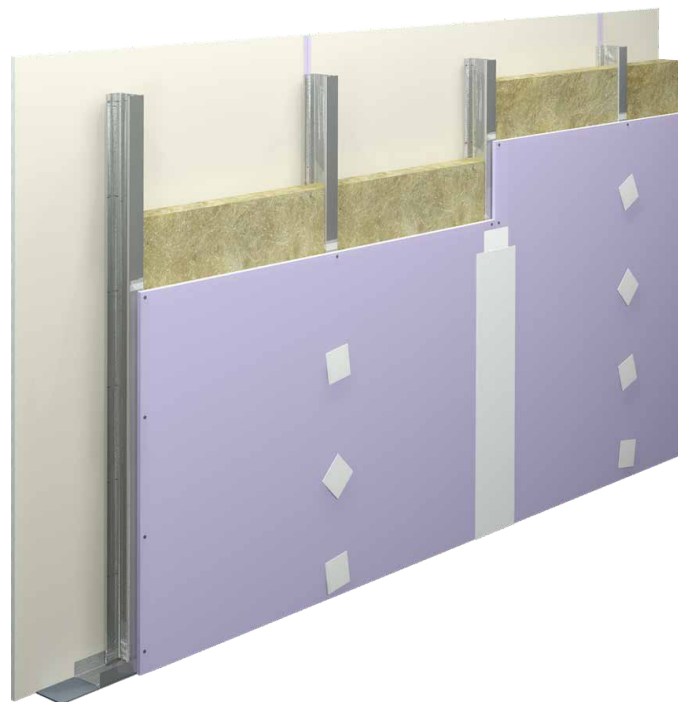

**Q2** Refilling screw openings and plasterboard joints – larger width (min. 25 cm)



**Q3** Filling the entire structure surface

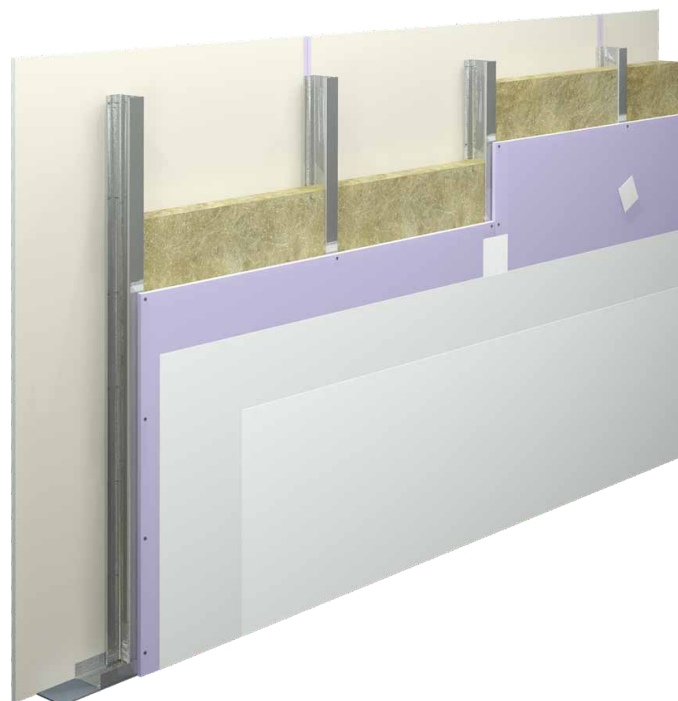

**Q4** Additional filling of the entire structure surface

# JOINT FILLING LEVELS

Dedicated products at individual levels

Q1



Q2



Q3



Q4



# PROFILE EXTENSION

CW and UA wall profiles can be extended with a correct profile overlap ("u"), depending on the variant and profile width employed.

The "u" parameter is equal to, respectively:

- $u = 50$  cm for CW 50 and UA 50 profiles;
- $u = 75$  cm for CW 75 and UA 75 profiles;
- $u = 100$  cm for CW 100 and UA 100 profiles.

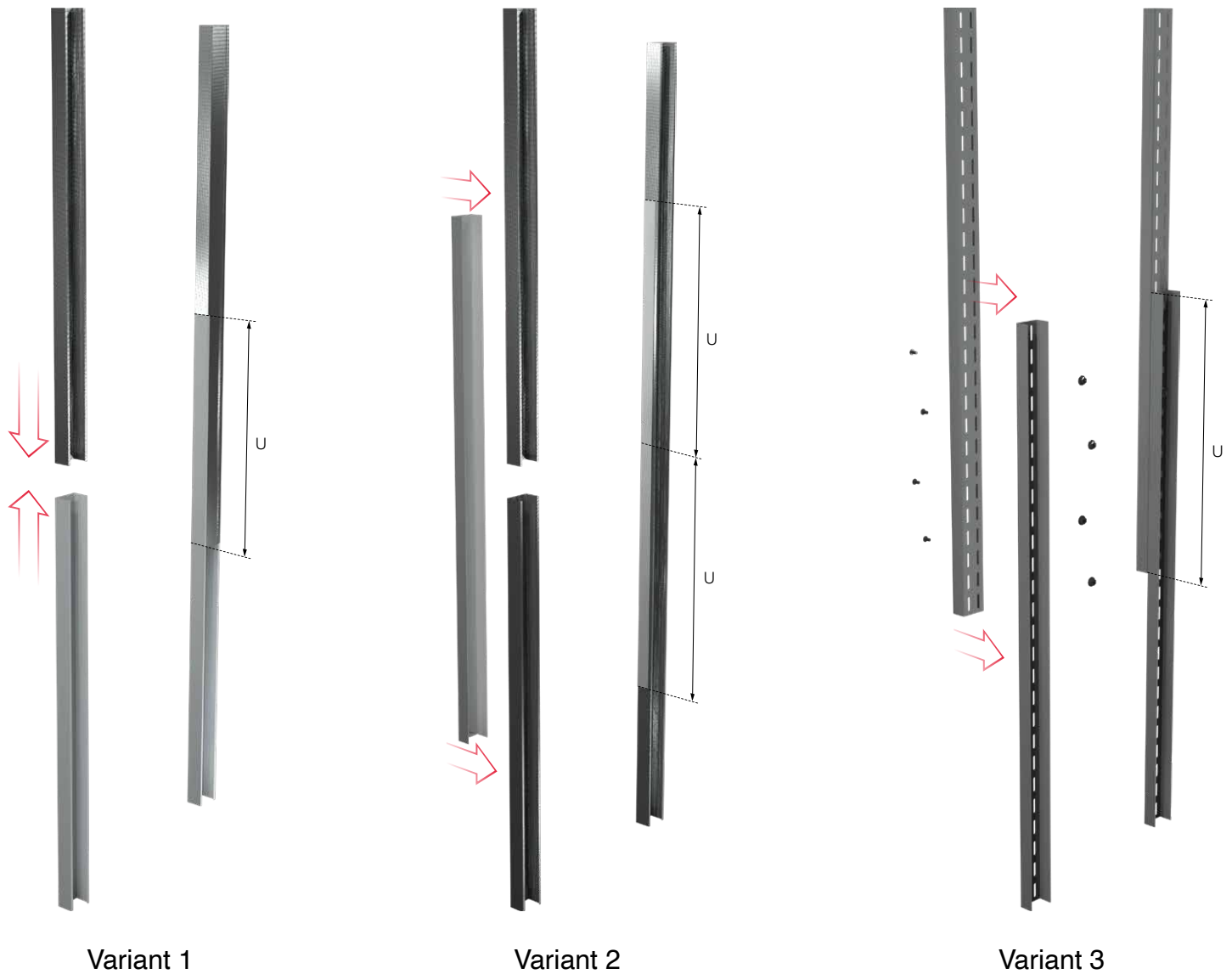

# ADDITIONAL HOLES IN PROFILES

Additional holes can be made in CW and UA profiles adhering to the following rules:

- Additional holes must be located in the profile web axis.
- No additional holes are allowed in the profiles where there are door or skylight openings are present or where loads are applied, e.g. by wall-mounted cabinets.
- Moreover, no additional profile holes are allowed if there are higher uniform wall loads, e.g. from gas-supplied extinguishing systems.
- The additional holes must be made as described in Table 1:

Table 1

Profile	Permissible number of additional holes	Additional hole size a x b [mm] (width x height)	Minimum distance between holes or minimum distance between a hole and edge 2 x b [mm] (2 x height)	Minimum sheathing thickness per each wall side
CW50	2	$\leq 30 \times \leq 50$	$\geq 100$	$\geq 18$
CW75	2	$\leq 55 \times \leq 75$	$\geq 150$	$\geq 12,5$
CW100	2	$\leq 80 \times \leq 100$	$\geq 200$	$\geq 12,5$
UA50	2	$\leq 30 \times \leq 50$	$\geq 100$	$\geq 12,5$
UA75	2	$\leq 55 \times \leq 75$	$\geq 150$	$\geq 12,5$
UA100	2	$\leq 80 \times \leq 100$	$\geq 200$	$\geq 12,5$

**UA 75  
and UA 100  
profiles**



**UA 50  
profile**

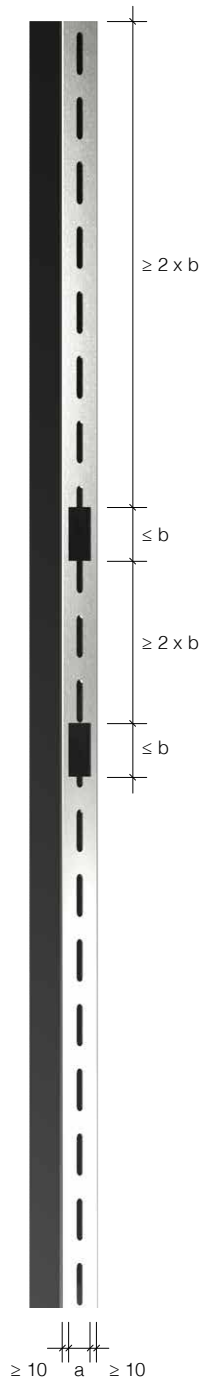

**CW 75  
and CW 100  
profiles**

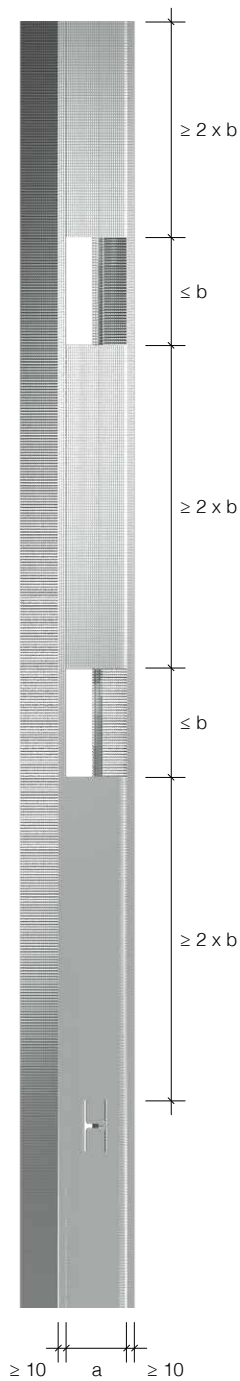

**CW 50  
profile**

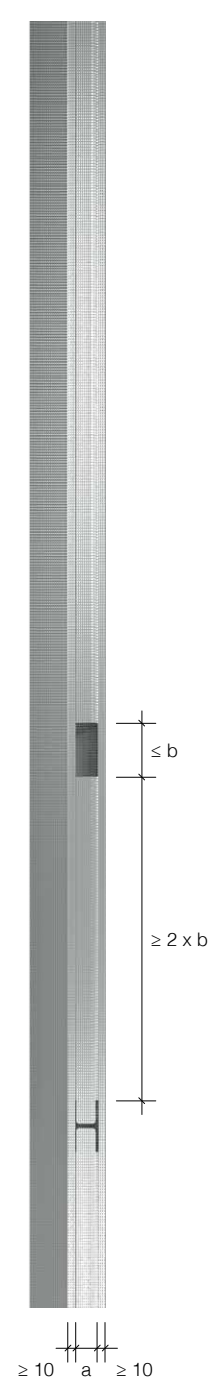

Where:

$a$  – hole width [mm]

$b$  – hole height (m)

# ADDITIONAL INFORMATION

## NORGIPS plasterboard installation rules

NORGIPS plasterboards should be installed at maximum ambient humidity of 70% and air temperature of at least +5°C. Boards must not be damp before installing. Higher ambient humidity may adversely affect plasterboard properties.

Taking into account moisture-related requirements for plasterboards, installation of drywall elements should be commenced after the completion of “wet” works, i.e. after underlayment placement, brick wall plastering, etc.

If the above cannot be accomplished due to the sequence of works on the construction site, plasterboards must be secured against moisture as required.

### Selection of a U profile (or two angle sections – 2L) for wall height > 6.5 m

The type (variant) of a wall-ceiling joint and dimensions “a” i “b” while installing CW100 posts should be selected as described in Table 2 below:

Table 2

		$\Delta V_f$ – ceiling sag [mm]				
		0	10	20	30	40
$\Delta y_f$ – post top shift [mm]	0	U100 / 100 a=30 / b=70	U100 / 100 a=30 / b=70	U100 / 100 a=30 / b=70	U100 / 100 a=30 / b=70	U100 / 100 a=40 / b=60
	10	U100 / 100 a=30 / b=70	U100 / 100 a=30 / b=70	U100 / 100 a=30 / b=70	U100 / 100 a=40 / b=60	U100 / 100 a=50 / b=50
	20	U100 / 100 a=30 / b=70	U100 / 100 a=30 / b=70	U100 / 100 a=40 / b=60	U100 / 100 a=50 / b=50	U100 / 120 a=60 / b=60
	30	U100 / 100 a=30 / b=70	U100 / 100 a=40 / b=60	U100 / 100 a=50 / b=50	U100 / 120 a=60 / b=60	U100 / 140 a=70 / b=70
	40	U100 / 100 a=40 / b=60	U100 / 100 a=50 / b=50	U100 / 120 a=60 / b=60	2L 100 / 140 a=70 / b=70	2L 100 / 140 a=80 / b=60
	50	U100 / 100 a=50 / b=50	U100 / 120 a=60 / b=60	U100 / 120 a=70 / b=50	2L 100 / 140 a=80 / b=60	2L 100 / 140 a=90 / b=50

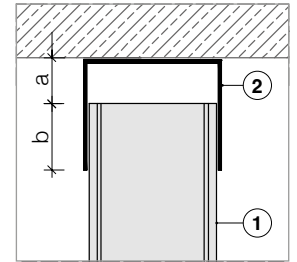

#### Joint elements:

1. CW profile
2. U profile

Additional conditions to be fulfilled while selecting the upper joint for a high wall:

$$\Delta V_f + \Delta y_f \leq a - \text{post top upward shift}$$

$$\Delta V_f + b > 0 - \text{post top downward shift}$$

Unless the design calculations regarding fire protection conditions show otherwise, the following should be adopted:

- $\Delta V_f$  post top upward shift as per Table 3;
- $\Delta V_f$  post top downward shift equal to  $\Delta V_f \leq -50$  mm
- $\Delta y_f$  ceiling sag equal to the design ceiling sag assumed while creating a design for standard conditions

Table 3

Wall height H [m]	$\Delta y_f$ post top shift [mm]
6,00	20
7,00	25
8,00	30
9,00	35
10,00	40

# **NORGIPS solutions**

---

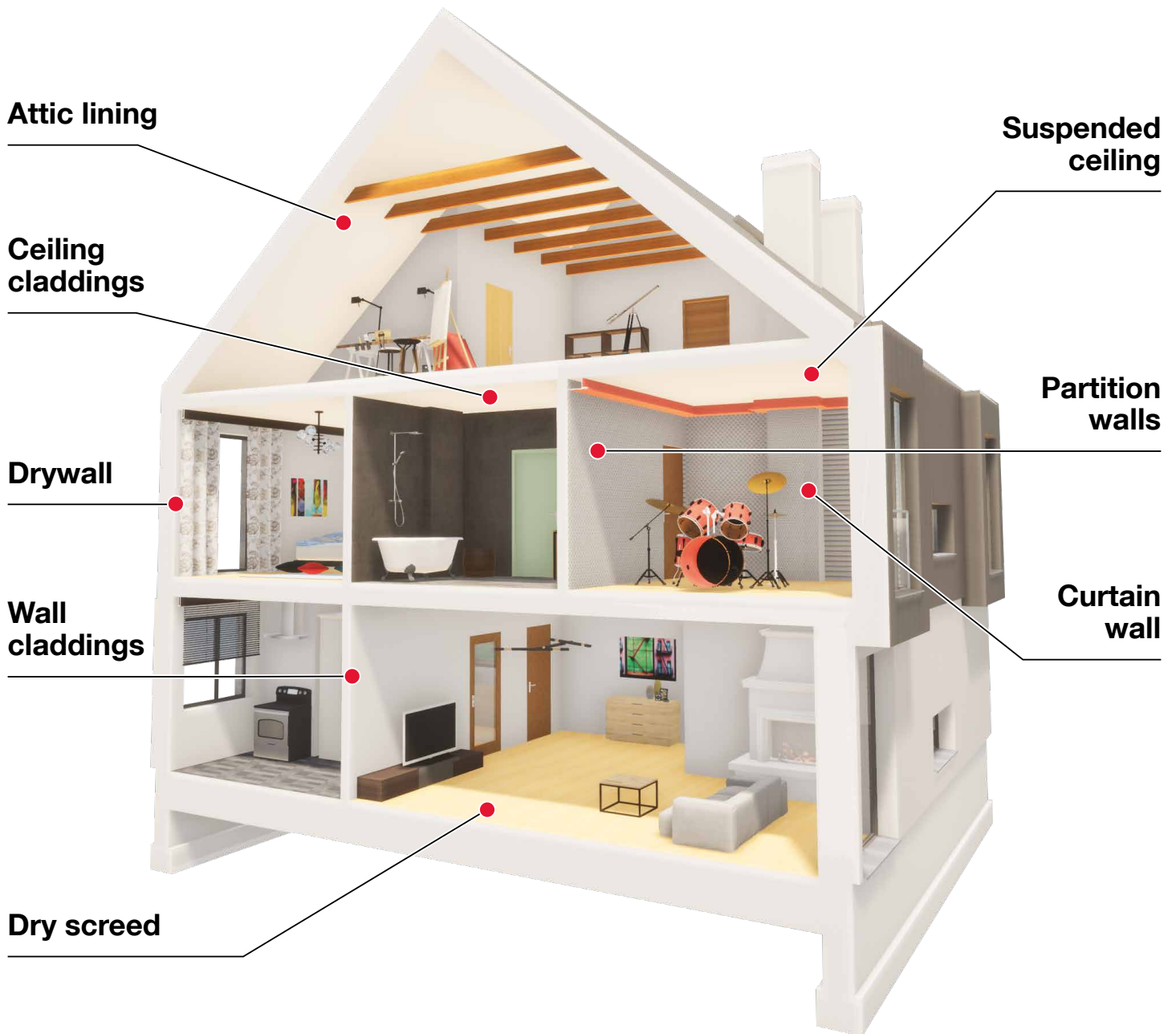

**NORGIPS** solutions comprise tried-and-tested materials to guarantee safety and comfort of use

---

Learn more about our solutions and check the full range of NORGIPS drywall materials at

**[www.norgips.pl](http://www.norgips.pl)**

# NORGIPS®

**1 ESTONIA**  
**Tanel Kuusik**  
Country Manager  
+372 562 043 35  
tanel.kuusik@norgips.com

**2 LATVIA**  
**Artis Meikšāns**  
Country Manager  
+371 67 47 06 14  
artis.meiksans@norgips.com

**3 LITHUANIA**  
**Aurelijus Motiejūnas**  
Country Manager  
+370 69 810 088  
aurelijus.Motiejunas@norgips.com

**4 CZECH REPUBLIC**  
**Pavel Holeš**  
Country Manager  
+420 732 213 409  
pavel.holes@norgips.com

**5 SLOVAKIA**  
**Aida Halák**  
Sales Representative  
+421 948 768 045  
aida.halak@norgips.com

**6 HUNGARY**  
**Tamás Horváth**  
Country Manager Hungary  
+36 20 917 2520  
tamas.horvath@norgips.com

**7 CROATIA**  
**Denis Halas**  
Sales Representative  
+48 695 230 568  
denis.halas@norgips.com

**8 BOSNIA AND HERZEGOVINA**  
**Maria Mitova**  
Country Manager  
+359 (0) 885 713 267  
maria.mitova@norgips.com

**9 ROMANIA**  
**Nicolae Alexandrescu**  
Country Manager  
+40 726 502 134  
nicolae.alexandrescu@norgips.com

**Alexandru Pitac**  
Technical Advisor  
+40 756 125 288  
alexandru.pitac@norgips.com

**10/11 BULGARIA and SERBIA**  
**Maria Mitova**  
Country Manager  
+359 (0) 885 713 267  
maria.mitova@norgips.com

**Jānis Muižnieks**  
Sales Coordinator  
+371 26 549 917  
janis.muiznieks@norgips.com

**Andrej Litovčenko**  
Sales Coordinator  
+370 620 718 60  
andrej.litovcenko@norgips.com

**Jaroslav Slanina**  
Sales Representative  
+420 774 731 232  
jaroslav.slantina@norgips.com

**Gábor Donka**  
Technical Advisor  
+36 30 543 5498  
gabor.donka@norgips.com

**Cristian Roman**  
Product Manager  
+40 746 119 932  
cristian.roman@norgips.com

**Nikolay Kolev**  
Sales Representative  
+359 (0) 885 929 680  
nikolay.kolev@norgips.com

**Dariusz Nasiłowski**  
**Export Director CEE Region**  
+48 605 338 181  
dariusz.nasilowski@norgips.com



## COMPANY HEADQUARTERS IN WARSAW

**Norgips Sp. z o.o.**  
Krakowiaków 50 (The Park Warsaw)  
02-634 Warszawa, POLAND  
+48 605 338 181  
norgipspolska@norgips.com

2026

[www.norgips.eu](http://www.norgips.eu)