



GROUP OF TESTING LABORATORIES GRYFITLAB

ul. Prosta 2, Łozienica, 72-100 Goleniów
phone (91) 431 82 29, fax (91) 418 97 57, mobile: +48 607 900 480
www.gryfitlab.com, e-mail: contact@gryfitlab.com

Fire resistance classification No. LBO – 062 – KZ/25E

Classified product:

**Suspended ceilings Norgips
lined with 12.5 mm thick gypsum plasterboards
Norgips GKF type DF, Norgips GKFI type DFH2 and
Norgips Acoustic Super type DFH2IRE**

Sponsor:

Norgips Sp. z o.o.
ul. Krakowiaków 50
02-255 Warszawa

Prepared by:

Group of Testing Laboratories Gryfitlab
ul. Prosta 2, Łozienica
72-100 Goleniów

Place and date of issue:

Łozienica, 12.11.2025 r.

Copy No. 1

The classification was printed in 3 copies. Copies Nos. 1, 2 – for the Sponsor, Copy No. 3 – AA

GRYFITLAB Sp. z o.o. - ul. Prosta 2, Łozienica - 72-100 Goleniów - Polska - tel.: (48) 91 431 82 45 - fax.: (48) 91 431 82 46

NIP 955-21-28-725, KRS:0000236527, Sąd Rejonowy w Szczecinie, XVII Wydział Gospodarczy KRS, Kapitał zakładowy 1 200 000 PLN

1. This classification has been prepared based on the following documents:

- 1.1. Standard PN-EN 13501-2:2023-09 Fire classification of construction products and building elements – Part 2: Classification using data from fire resistance tests, excluding ventilation services.
- 1.2. Standard PN-EN 1364-2:2018-02 Fire resistance tests for non-loadbearing elements – Part 2: Ceilings.
- 1.3. Standard PN-EN 1363-1:2020-07 Fire resistance tests – Part 1: General requirements.
- 1.4. Report No. LZP01-6041/15/R23NZN Suspended ceiling Norgips SP-1x12.5 GKF DF/CD 60 manufactured by Norgips, lined with 1x12.5 mm thick gypsum plasterboards Norgips GKF type DF, with a two level grid made of steel profiles Norgips CD 60 x 27, with rotating steel hangers with noniuses. Fire Tests Laboratory, Building Research Institute (Instytut Techniki Budowlanej), Warsaw 2016.
- 1.5. Drawings and technical documentation provided by the Sponsor.

2. Technical description of suspended ceilings

2.1 Suspended ceilings SP – 1x12.5 GKF DF/CD60, SP – 1x12.5 GKFI DFH2/CD60 and SP – 1x12.5 DFH2IR/CD60, lined with 1x12.5 mm thick gypsum plasterboards Norgips GKF type DF or Norgips GKFI type DFH2 or Norgips Acoustic Super type DFH2IRE, with two level grids

The construction of the ceilings consists of a two level grid. The grid is made of profiles e.g. **Norgips CD 60**. The profiles are made of cold bent galvanized steel; the nominal thickness of the steel used is **0.55 mm** (tolerance: +/- 0.06 mm) or **0.6 mm** (tolerance: +/- 0.06 mm). The profiles of the main (top) layer are placed maximally every **100 cm** and this distance is measured between the axes of the adjacent profiles. The profiles of the loadbearing (bottom) layer are placed maximally every **40 cm** and this distance is measured between the axes of the adjacent profiles. The profiles of the main and loadbearing layer are connected with one another by means of e.g. **Norgips cross connectors** (min. operational load 350 N) for profiles CD 60. The profiles of the main layer are suspended by means of e.g. **rotating hangers with spring Norgips** or e.g. **rotating hangers with nonius Norgips** (min. operational load 320 N) or by applying hangers e.g. **Norgips ES 60** (min. operational load 750 N) or **Norgips ES 60 plus** fixed to the construction of a floor or to the construction of a roof by means of two mechanical connectors, such as e.g.: steel dowels, screws, etc. Profiles **CD 60** of the main layer are fixed to hangers **ES 60** or **ES 60 plus** by means of 4 sheet steel screws **Ø 3.9 x 11 mm** or **Ø 3.5 x 9.5 mm** with self-drilling endings. The hangers are placed maximally every **85 cm**.

Cold bent steel profiles e.g. **Norgips UD 30** (system profiles) are fixed on the perimeter of the ceiling by means of mechanical connectors, such as e.g.: steel dowels, screws, etc. of the minimum dimensions of **Ø 6 x 40 mm** and placed maximally every **60 cm**.

Gypsum plasterboards **Norgips GKF type DF** (thickness: **1 x 12.5 mm**) or **Norgips GKFI type DFH2** (thickness: **1 x 12.5 mm**) or **Norgips Acoustic Super type DFH2IRE** (thickness: **1 x 12.5 mm**) of the minimum surface density equal to at least 10 kg/m² are fixed to the profiles of the loadbearing layer.

The layer of the plasterboards is fixed by means of system sheet steel screws e.g. **Norgips Ø 3.5 x 25 mm**, placed at maximally **17 cm** centres.

The plasterboards are fixed in such a way as to ensure that their longer edges are perpendicular to the profiles of the loadbearing layer. The joints between shorter edges of boards always have to be placed within profiles **CD 60**. Adjacent shorter edges of boards have to be shifted in relation to one another by minimally **40 cm**.

The screw heads as well as the joints between the **Norgips GKF** plasterboards **type DF** or the **Norgips GKFI** plasterboards **type DFH2** or the **Norgips Acoustic Super** plasterboards **type DFH2IRE** are filled with gypsum filler e.g. **Norgips Start**, **Norgips Super Filler** or **Norgips Start & Finish (Norgips Light Ready Mix)**. The joints between the boards are additionally strengthened with Norgips system self-adhesive reinforcing tape made of glass fibre or with reinforcing tape made of interlining. For final covering, it is recommended to use ready mix jointing compound e.g. **Norgips Easy Finish**, **Norgips Extra Finish**, **Norgips Start & Finish (Norgips Light Ready Mix)** or gypsum finish **Norgips Finish**. Details of the construction of the suspended ceilings are presented in **Figures 1 – 6**.

If the diagonal of the suspended ceiling is longer than 15 m or in places where there are constructional expansion joints of a building, one should provide expansion joints in the suspended ceiling (**Figure 15**).

2.2 Suspended ceilings SPJ – 1x12.5 GKF DF/CD60, SPJ – 1x12.5 GKFI DFH2/CD60 and SPJ – 1x12.5 DFH2IR/CD60 lined with 1x12.5 mm thick gypsum plasterboards Norgips GKF type DF or Norgips GKFI type DFH2 or Norgips Acoustic Super type DFH2IRE, with one level grids

The construction of the ceilings consists of a one level grid. The grid is made of system profiles e.g. **Norgips CD 60**. The profiles are made of cold bent galvanized steel; the nominal thickness of the steel used is **0.55 mm** (tolerance: +/- 0.06 mm) or **0.6 mm** (tolerance: +/- 0.06 mm). Main profiles are placed maximally every **120 cm** and this distance is measured between the axes of the adjacent profiles. Lateral profiles are placed maximally every **40 cm** and this distance is measured between the axes of the adjacent profiles. The lateral profiles and the main profiles are connected with one another by means of e.g. **Norgips lateral single-sided connectors** for profiles **CD 60**. These connectors are slid into the lateral profiles and then screwed with them by means of 2 sheet steel screws (**Ø 3.9 x 11 mm** or **Ø 3.5 x 9.5 mm**) with self-drilling endings. Then, the lateral profiles are slid into the main profiles in such a way that a fastener of the lateral single-sided connector is slid into a web of the main profile. Then, the lateral single-sided connector is screwed to the main profile by means of 2 sheet steel screws (**Ø 3.9 x 11 mm** or **Ø 3.5 x 9.5 mm**) with self-drilling endings. The main profiles are suspended by means of system **rotating hangers with spring** e.g. **Norgips** or **rotating hangers with nonius** e.g. **Norgips** (min. operational load 320 N) or by applying system hangers e.g. **Norgips ES 60** (min. operational load 750 N) or **Norgips ES 60 plus** fixed to the construction of a floor or to the construction of a roof by means of two mechanical connectors, such as steel dowels, screws, etc. Main profiles **CD 60** are fixed to hangers **ES 60** or **ES 60 plus** by means of 4 sheet steel screws

Ø 3.9 x 11 mm or Ø 3.5 x 9.5 mm with self-drilling endings. The hangers are placed maximally every 70 cm.

Cold bent steel profiles e.g. **Norgips UD 30** are fixed on the perimeter of the ceiling by means of mechanical connectors, such as, e.g.: steel dowels, screws, etc. of the minimum dimensions of Ø 6 x 40 mm and placed maximally every 60 cm.

Gypsum plasterboards **Norgips GKF type DF** (thickness: 1 x 12.5 mm) or **Norgips GKFI type DFH2** (thickness: 1 x 12.5 mm) or **Norgips Acoustic Super type DFH2IRE** (thickness: 1 x 12.5 mm) of the minimum surface density equal to at least 10 kg/m² are fixed to the main profiles and to the lateral profiles.

The layer of the plasterboards is fixed by means of system sheet steel screws Ø 3.5 x 25 mm, placed at maximally 17 cm centres.

The plasterboards are fixed in such a way as to ensure that their longer edges are perpendicular to the lateral profiles. The joints between shorter edges of boards always have to be placed within lateral profiles. Adjacent shorter edges of boards have to be shifted in relation to one another by minimally 40 cm.

The screw heads as well as the joints between the **Norgips GKF** plasterboards **type DF** or the **Norgips GKFI** plasterboards **type DFH2** or the **Norgips Acoustic Super** plasterboards **type DFH2IRE** are filled with system gypsum filler e.g. **Norgips Start**, **Norgips Super Filler** or **Norgips Start & Finish (Norgips Light Ready Mix)**. The joints between the boards are additionally strengthened with Norgips system self-adhesive reinforcing tape made of glass fibre or with reinforcing tape made of interlining. For final covering, it is recommended to use ready mix jointing compound e.g. **Norgips Easy Finish**, **Norgips Extra Finish**, **Norgips Start & Finish (Norgips Light Ready Mix)** or gypsum finish **Norgips Finish**. Details of the construction of the suspended ceilings are presented in **Figures 7 – 9**.

If the diagonal of the suspended ceiling is longer than 15 m or in places where there are constructional expansion joints of a building, one should provide expansion joints in the suspended ceiling.

2.3 Ceiling linings OSF – 1x12.5 GKF DF/CD60, OSF – 1x12.5 GKFI DFH2/CD60 and OSF – 1x12.5 DFH2IR/CD60, lined with 1x12.5 mm thick gypsum plasterboards Norgips GKF type DF or Norgips GKFI type DFH2 or Norgips Acoustic Super type DFH2IRE

The construction of the ceiling linings consists of system profiles e.g. **Norgips CD 60**. The profiles are made of cold bent galvanized steel; the nominal thickness of the steel used is **0.55 mm** (tolerance: +/- 0.06 mm) or **0.6 mm** (tolerance: +/- 0.06 mm); the profiles are placed every **40 cm** and this distance is measured between the axes of the adjacent profiles.

The profiles used are suspended by applying system hangers e.g. **Norgips ES 60/75, 60/125** (min. operational load 750 N) or **Norgips ES plus 60/60, 60/120** or **Norgips L-type flat hangers** (L-180, L-270, L-350) fixed to the construction of a floor or to the construction of a roof by means of 2 mechanical connectors, such as, e.g.: steel dowels, screws,

etc. Profiles **CD 60** are fixed to hangers **ES 60** or **ES 60 plus** by means of 4 sheet steel screws $\varnothing 3.9 \times 11 \text{ mm}$ or $\varnothing 3.5 \times 9.5 \text{ mm}$ with self-drilling endings. The L-hanger are fixed to timber beams by 2 wood screws $\varnothing 3.5 \times 35 \text{ mm}$. The hangers are placed maximally every **85 cm**.

Cold bent steel profiles e.g. **Norgips UD 30** are fixed on the perimeter of the ceiling by means of mechanical connectors, such as, e.g.: steel dowels, screws, etc. of the minimum dimensions of $\varnothing 6 \times 40 \text{ mm}$ and placed maximally every **60 cm**.

Gypsum plasterboards **Norgips GKF type DF** (thickness: **1 x 12.5 mm**) or **Norgips GKFI type DFH2** (thickness: **1 x 12.5 mm**) or **Norgips Acoustic Super type DFH2IRE** (thickness: **1 x 12.5 mm**) of the minimum surface density equal to at least 10 kg/m^2 are fixed to the **CD 60** profiles.

The layer of the plasterboards is fixed by means of system sheet steel screws $\varnothing 3.5 \times 25 \text{ mm}$, placed at maximally **17 cm** centres.

The plasterboards are fixed in such a way as to ensure that their longer edges are perpendicular to the **CD 60** profiles. The joints between shorter edges of boards in the lateral layout always have to be placed within profiles **CD 60**. Adjacent shorter edges of boards have to be shifted in relation to one another by minimally **40 cm**.

The screw heads as well as the joints between the **Norgips GKF** plasterboards **type DF** or the **Norgips GKFI** plasterboards **type DFH2** or the **Norgips Acoustic Super** plasterboards **type DFH2IRE** are filled with gypsum filler e.g. **Norgips Start**, **Norgips Super Filler** or **Norgips Start & Finish (Norgips Light Ready Mix)**. The joints between the boards are additionally strengthened with e.g. Norgips system self-adhesive reinforcing tape made of glass fibre or with reinforcing tape made of interlining. For final covering, it is recommended to use ready mix jointing compound e.g. **Norgips Easy Finish**, **Norgips Extra Finish**, **Norgips Start & Finish (Norgips Light Ready Mix)** or gypsum finish **Norgips Finish**. Details of the construction of the ceiling linings are presented in **Figures 10 - 11**.

If the diagonal of the ceiling lining is longer than 15 m or in places where there are constructional expansion joints of a building, one should provide expansion joints in the ceiling lining.

2.4 Ceiling linings OSF – 1x12.5 GKF DF/KAP, OSF – 1x12.5 GKFI DFH2/KAP and OSF – 1x12.5 DFH2IR/KAP, lined with 1x12.5 mm thick gypsum plasterboards Norgips GKF type DF or Norgips GKFI type DFH2 or Norgips Acoustic Super type DFH2IRE

The construction of the ceiling linings consists of e.g. **Norgips system hat** profiles. The profiles are made of cold bent galvanized steel; the nominal thickness of the steel used is **0.55 mm** (tolerance: $\pm 0.06 \text{ mm}$) or **0.6 mm** (tolerance: $\pm 0.06 \text{ mm}$); the profiles are placed every **40 cm** and this distance is measured between the axes of the adjacent profiles.

The profiles are fixed to the construction of a floor or to the construction of a roof by means of 2 mechanical connectors, such as e.g.: steel dowels, screws, etc. of the minimum dimensions of $\varnothing 6 \times 40 \text{ mm}$ placed maximally every **100 cm**.

Gypsum plasterboards **Norgips GKF type DF** (thickness: **1 x 12.5 mm**) or **Norgips GKFI type DFH2** (thickness: **1 x 12.5 mm**) or **Norgips Acoustic Super type DFH2IR** (thickness: **1 x 12.5 mm**) of the minimum surface density equal to at least 10 kg/m² are fixed to the **hat** profiles.

The layer of the plasterboards is fixed by means of system sheet steel screws **Ø 3.5 x 25 mm**, placed at maximally **17 cm** centres.

The plasterboards are fixed in such a way as to ensure that their longer edges are perpendicular to the **hat** profiles. The joints between shorter edges of boards in the lateral layout always have to be placed within **hat** profiles. Adjacent shorter edges of boards have to be shifted in relation to one another by minimally **40 cm**.

The screw heads as well as the joints between the **Norgips GKF** plasterboards **type DF** or the **Norgips GKFI** plasterboards **type DFH2** or the **Norgips Acoustic Super** plasterboards **type DFH2IRE** are filled with system gypsum filler e.g. **Norgips Start** or **Norgips Super Filler**. The joints between the boards are additionally strengthened with Norgips system self-adhesive reinforcing tape made of glass fibre or with reinforcing tape made of interlining. For final covering, it is recommended to use putty **Norgips Easy Finish**, **Norgips Extra Finish**, **Norgips Start & Finish (Norgips Light Ready Mix)** or gypsum finish **Norgips Finish**. Details of the construction of the ceiling linings are presented in **Figures 12 - 14**.

If the diagonal of the ceiling lining is longer than 15 m or in places where there are constructional expansion joints of a building, one should provide expansion joints in the ceiling lining.

3. Fire resistance tests

The fire resistance test of the Norgips suspended ceiling made of 1x12.5 mm thick gypsum plasterboards Norgips GKF type DF was carried out in the Fire Tests Laboratory of the Building Research Institute (Instytut Techniki Budowlanej) in Warsaw.

Test report No. LZP01-6041/15/R23NZZ [1.4].

4. Fire resistance classification of suspended ceilings Norgips lined with 12.5 mm thick gypsum plasterboards Norgips GKF type DF, Norgips GKFI type DFH2 and Norgips Acoustic Super type DFH2IRE

Based on the analysis of test results indicated in item 3, suspended ceilings Norgips lined with 12.5 mm thick gypsum plasterboards Norgips GKF type DF, Norgips GKFI type DFH2 and Norgips Acoustic Super type DFH2IRE, manufactured and installed in accordance with the technical description presented in item 2, are classified according to standard PN-EN 13501-2:2023-09 [1.1] as belonging to the following fire resistance class:

EI 15 (a←b)

5. Independent suspended ceilings Norgips lined with 12.5 mm thick gypsum plasterboards Norgips GKF type DF, Norgips GKFI type DFH2 or Norgips Acoustic Super type DFH2IRE, used as fire separation

Horizontal fire separation elements, in the form of a floor or a flat roof with suspended ceiling Norgips lined with 12.5 mm thick gypsum plasterboards Norgips GKF type DF, Norgips GKFI type DFH2 and Norgips Acoustic Super type DFH2IRE, manufactured and installed in accordance with the technical description specified in item 2 herein, which – taking into account the classification provided in item 4 herein – constitute independent fire separation when being exposed to fire from below, meet the respective REI fire resistance criteria according to standard PN-EN 13501-2:2023-09 [1.1], as follows:

- Systems: floor – suspended ceiling and floor – ceiling lining (the construction of a floor is designed according to the Polish Standards and Eurocodes)
fire resistance class **REI 15 (a←b)**
- Systems: roof – suspended ceiling and roof – ceiling lining (the construction of a roof is designed according to the Polish Standards and Eurocodes)
fire resistance class **REI 15 (a←b)**

6. Validity

This classification is valid until 12.11.2030 on the condition that there are no changes in the construction or materials of the classified products.

Prezes Zarządu
Andrzej Szarycki

GRYFITLAB Sp. z o.o.
Zespół Laboratoriów
Badawczych Gryfitlab
ul. Prosta 2, Łozienica
72-100 GOLENIÓW

7. Figures

**Suspended ceilings Norgips
lined with 12.5 mm thick gypsum plasterboards
Norgips GKF type DF, Norgips GKFI type DFH2 and
Norgips Acoustic Super type DFH2IRE**

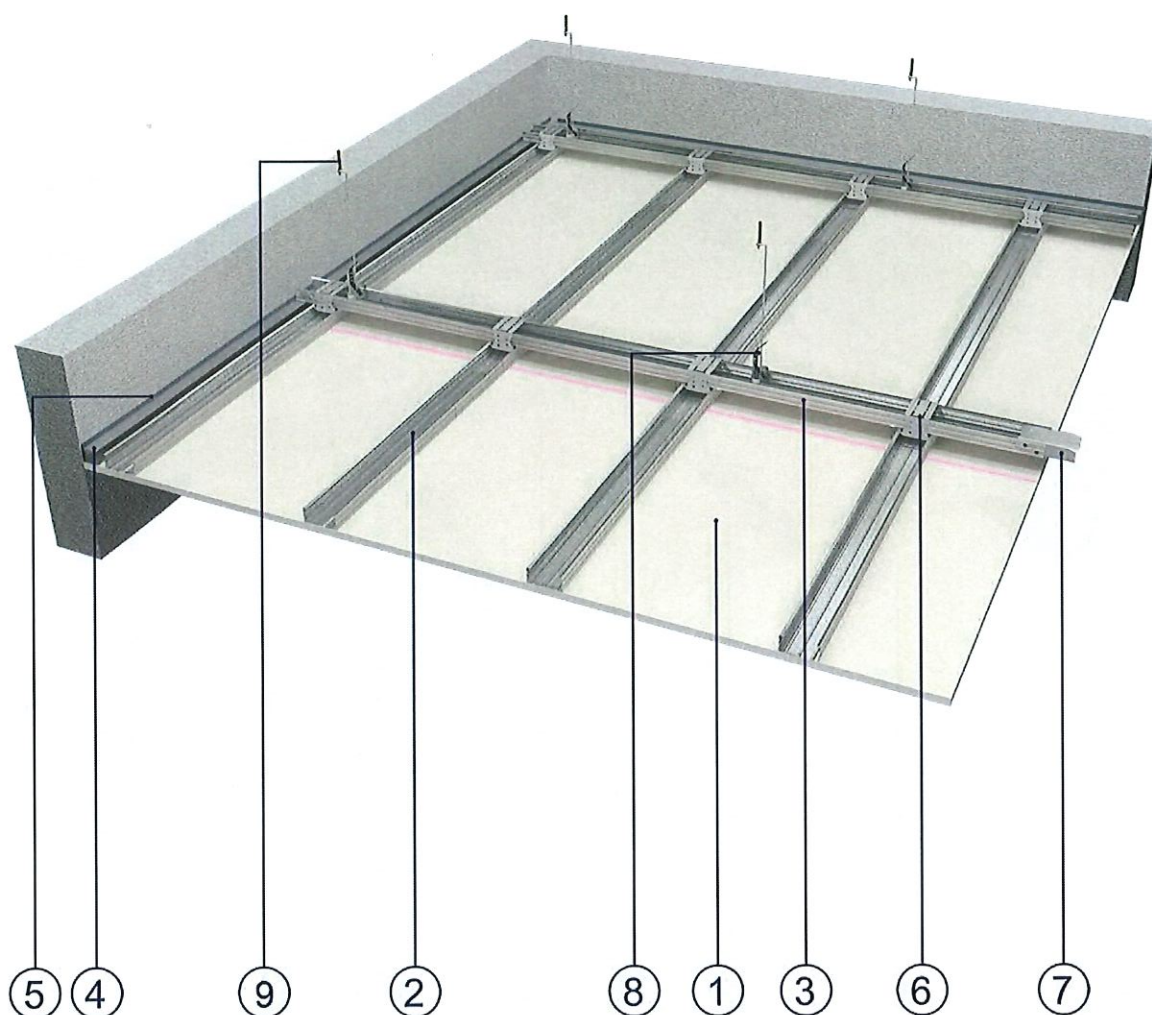

Elements of the ceiling

1. Gypsum plasterboards Norgips GKF type DF or Norgips GKFI type DFH2 or Norgips Acoustic Super type DFH2IRE, thickness: 1 x 12.5 mm
2. Profiles e.g. Norgips CD 60 of the loadbearing layer, minimum thickness: 0.55 mm, placed maximally every 40 cm (this distance is measured between the axes of the adjacent profiles)
3. Profiles e.g. Norgips CD 60 of the main layer, minimum thickness: 0.55 mm, placed maximally every 100 cm (this distance is measured between the axes of the adjacent profiles)
4. Profiles e.g. Norgips UD 30, minimum thickness: 0.55 mm
5. Sealing tape e.g. Norgips, width: 30 mm (recommended)
6. Cross connector e.g. Norgips for profiles CD 60
7. Longitudinal connector e.g. Norgips for profiles CD 60
8. Hanger e.g. Norgips: rotating hanger with spring, placed maximally every 85 cm (this distance is measured between the axes of the adjacent hangers)
9. Mechanical connector, e.g.: screw, steel dowel of the minimum dimensions of $\varnothing 6 \times 60$ mm

Figure 1 View of the suspended ceiling – two level cross construction with rotating hangers with springs

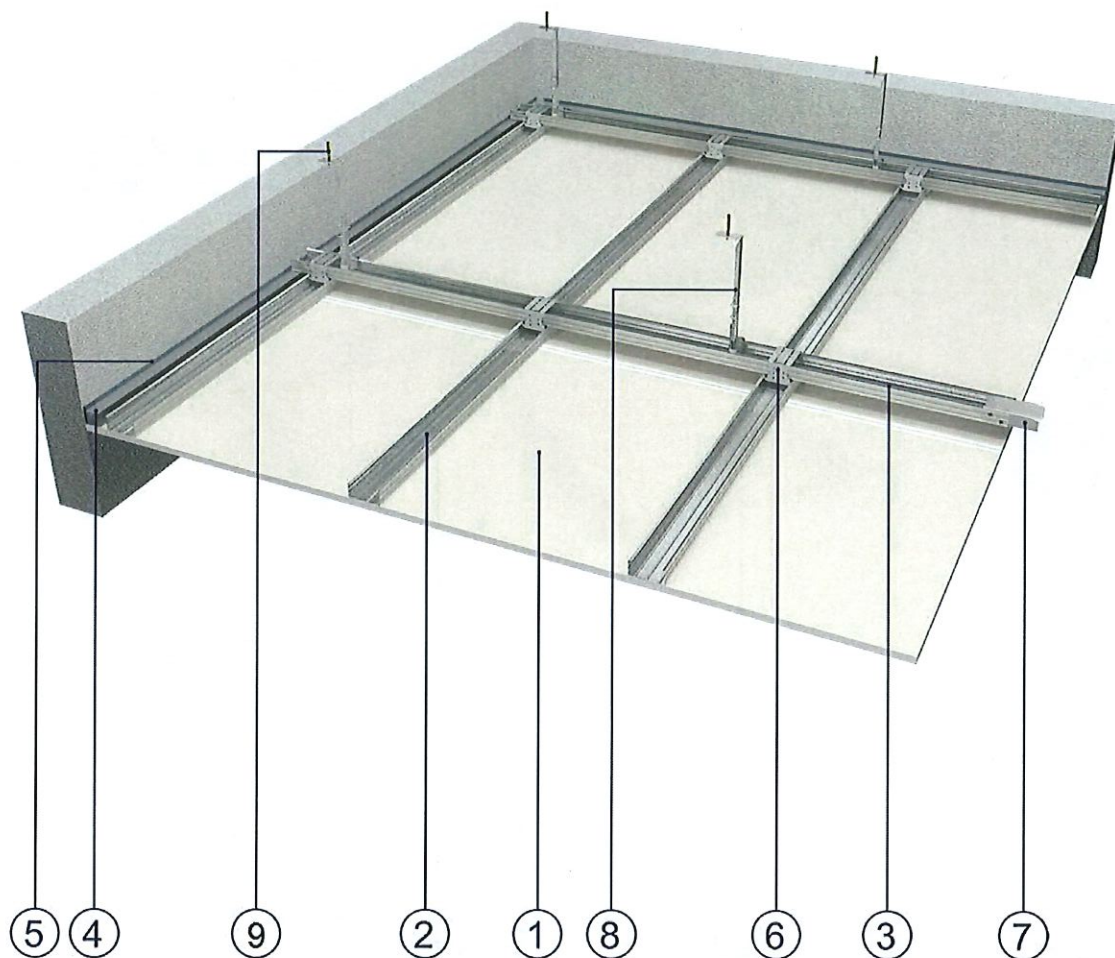

Elements of the ceiling

1. Gypsum plasterboards Norgips GKF type DF or Norgips GKFI type DFH2 or Norgips Acoustic Super type DFH2IRE, thickness: 1 x 12.5 mm
2. Profiles e.g. Norgips CD 60 of the loadbearing layer, minimum thickness: 0.55 mm, placed maximally every 40 cm (this distance is measured between the axes of the adjacent profiles)
3. Profiles e.g. Norgips CD 60 of the main layer, minimum thickness: 0.55 mm, placed maximally every 100 cm (this distance is measured between the axes of the adjacent profiles)
4. Profile e.g. Norgips UD 30, minimum thickness: 0.55 mm
5. Sealing tape e.g. Norgips, width: 30 mm (recommended)
6. Cross connector e.g. Norgips for profiles CD 60
7. Longitudinal connector e.g. Norgips for profiles CD 60
8. Hanger e.g. Norgips: rotating hanger with nonius, placed maximally every 85 cm (this distance is measured between the axes of the adjacent hangers)
9. Mechanical connector, e.g.: screw, steel dowel of the minimum dimensions of $\varnothing 6 \times 60$ mm

Figure 2 View of the suspended ceiling – two level cross construction with rotating hangers with noniuses

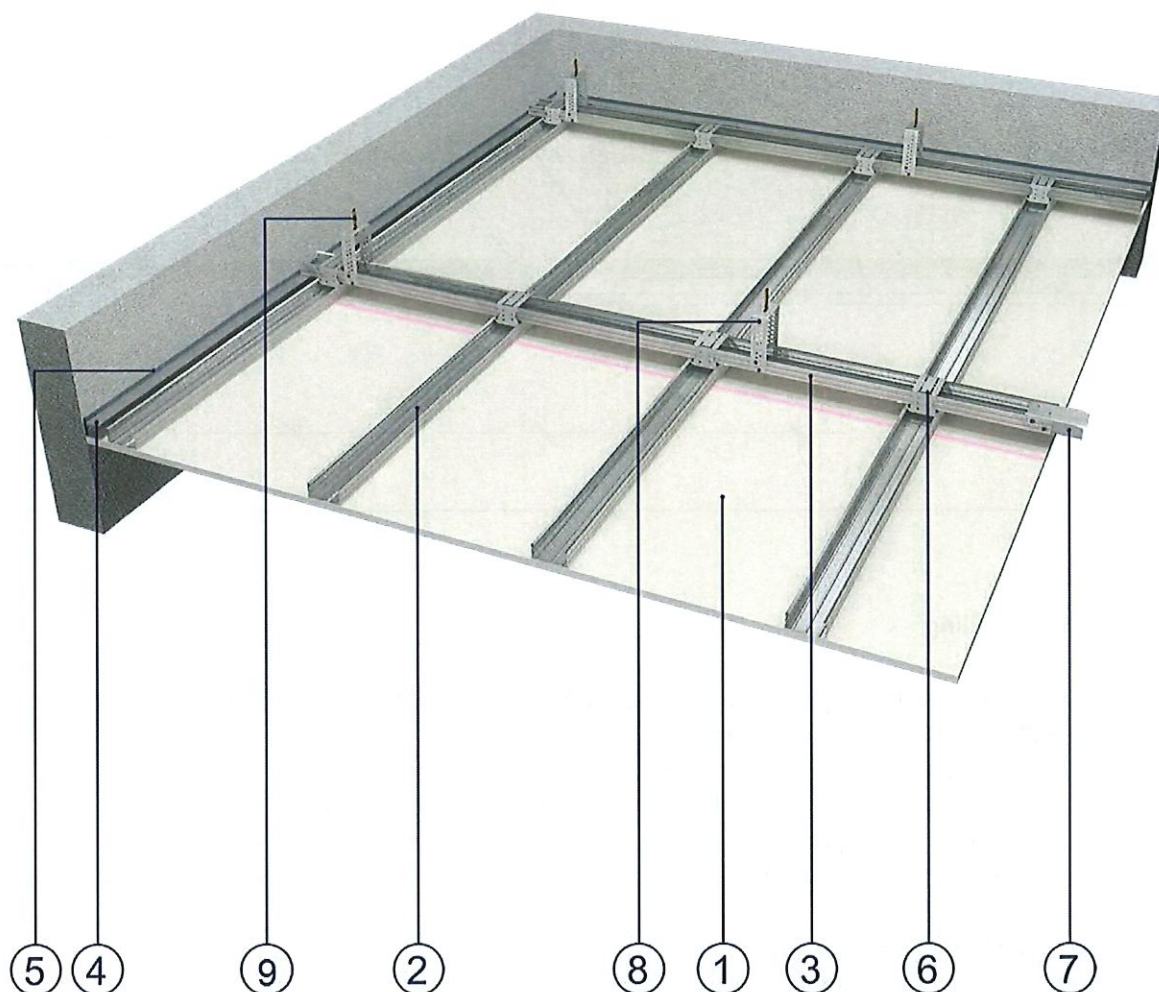

Elements of the ceiling

1. Gypsum plasterboards Norgips GKF type DF or Norgips GKFI type DFH2 or Norgips Acoustic Super type DFH2IRE, thickness: 1 x 12.5 mm
2. Profiles e.g. Norgips CD 60 of the loadbearing layer, minimum thickness: 0.55 mm, placed maximally every 40 cm (this distance is measured between the axes of the adjacent profiles)
3. Profiles e.g. Norgips CD 60 of the main layer, minimum thickness: 0.55 mm, placed maximally every 100 cm (this distance is measured between the axes of the adjacent profiles)
4. Profiles e.g. Norgips UD 30, minimum thickness: 0.55 mm
5. Sealing tape e.g. Norgips, width: 30 mm (recommended)
6. Cross connector e.g. Norgips for profiles CD 60
7. Longitudinal connector e.g. Norgips for profiles CD 60
8. Hanger e.g. Norgips ES or ES plus, placed maximally every 85 cm (this distance is measured between the axes of the adjacent hangers)
9. Mechanical connector, e.g.: screw, steel dowel of the minimum dimensions of $\varnothing 6 \times 60$ mm

Figure 3 View of the suspended ceiling – two level cross construction with hangers ES or ES plus

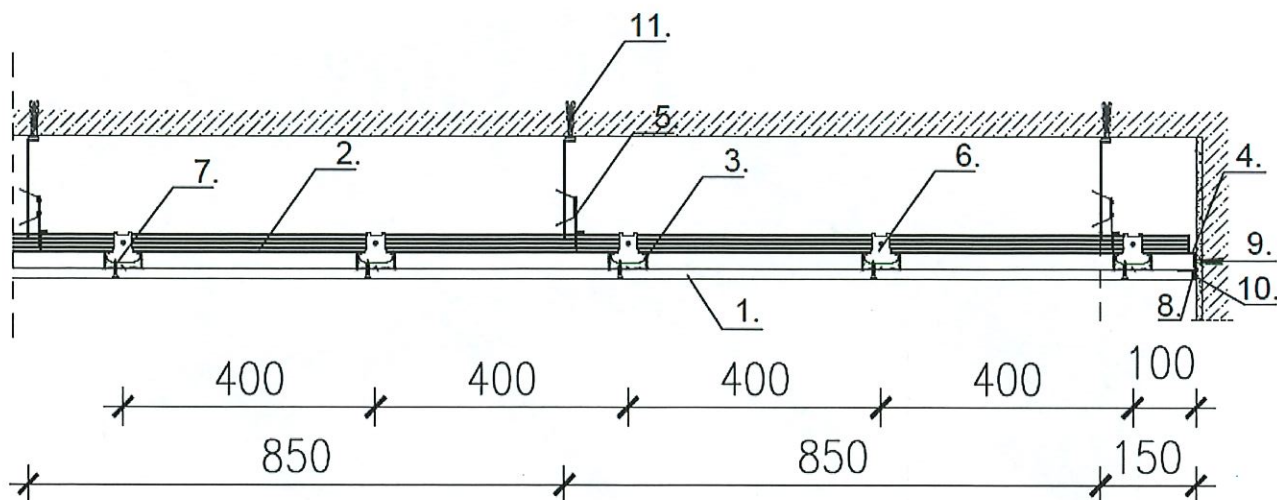

Elements of the ceiling

1. Gypsum plasterboards Norgips GKF type DF or Norgips GKFI type DFH2 or Norgips Acoustic Super type DFH2IRE, thickness: 1 x 12.5 mm
2. Profile e.g. Norgips CD 60 of the main layer, minimum thickness: 0.55 mm
3. Profile e.g. Norgips CD 60 of the loadbearing layer, minimum thickness: 0.55 mm
4. Profile e.g. Norgips UD 30, minimum thickness: 0.55 mm
5. Hanger e.g. Norgips: rotating hanger with spring or rotating hanger with nonius or hanger ES 60 or hanger ES 60 plus
6. Cross connector e.g. Norgips for profiles CD 60
7. Sheet steel screw e.g. Norgips 3.5 x 25 mm placed every 17 cm
8. Sealing tape e.g. Norgips, width: 30 mm (recommended)
9. Mechanical connector, e.g.: wall plug, dowel of the minimum dimensions of $\varnothing 6 \times 40$ mm
10. Gypsum filler e.g. Norgips Start, Norgips Super Filler or Norgips Start & Finish (Norgips Light Ready Mix)
11. Mechanical connector, e.g.: screw, steel dowel of the minimum dimensions of $\varnothing 6 \times 60$ mm

Figure 4 Longitudinal section of the suspended ceiling – two level cross construction

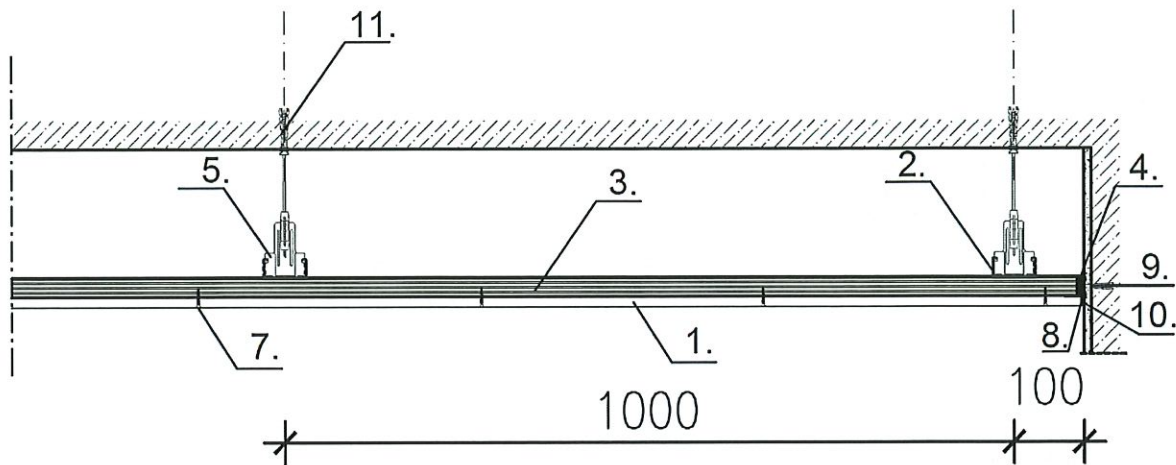

Elements of the ceiling

1. Gypsum plasterboards Norgips GKF type DF or Norgips GKFI type DFH2 or Norgips Acoustic Super type DFH2IRE, thickness: 1 x 12.5 mm
2. Profile e.g. Norgips CD 60 of the main layer, minimum thickness: 0.55 mm
3. Profile e.g. Norgips CD 60 of the loadbearing layer, minimum thickness: 0.55 mm
4. Profile e.g. Norgips UD 30, minimum thickness: 0.55 mm
5. Hanger e.g. Norgips: rotating hanger with spring or rotating hanger with nonius or hanger ES 60 or hanger ES 60 plus
6. Cross connector e.g. Norgips for profiles CD 60
7. Sheet steel screw e.g. Norgips 3.5 x 25 mm placed every 17 cm
8. Sealing tape e.g. Norgips, width: 30 mm (recommended)
9. Mechanical connector, e.g.: wall plug, dowel of the minimum dimensions of $\varnothing 6 \times 40$ mm
10. Gypsum filler e.g. Norgips Start, Norgips Super Filler or Norgips Start & Finish (Norgips Light Ready Mix)
11. Mechanical connector, e.g.: screw, steel dowel of the minimum dimensions of $\varnothing 6 \times 60$ mm

Figure 5 Cross section of the suspended ceiling – two level cross construction

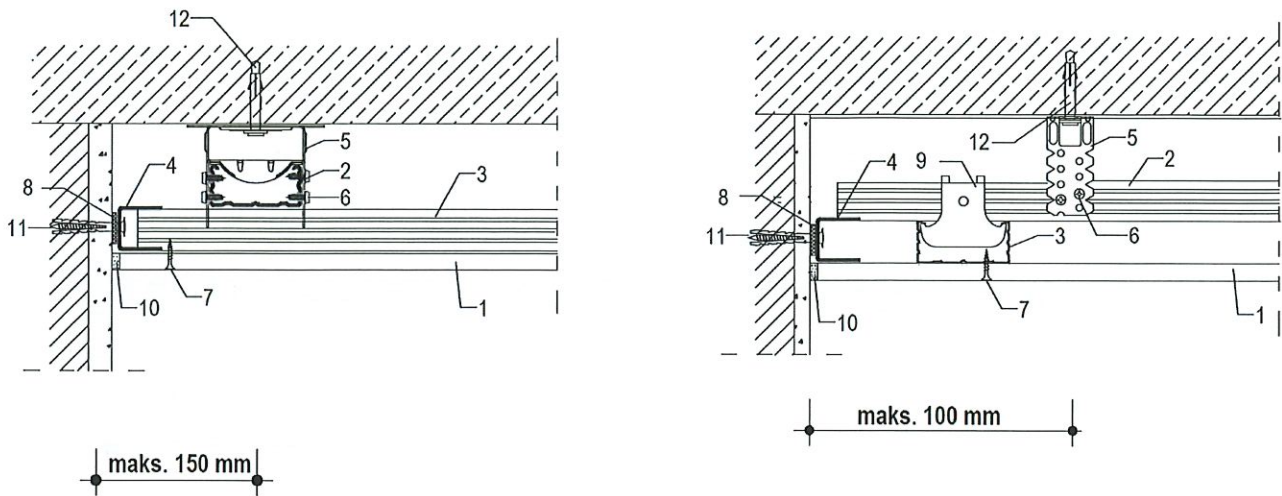

Elements of the ceiling

1. Gypsum plasterboards Norgips GKF type DF or Norgips GKFI type DFH2 or Norgips Acoustic Super type DFH2IRE, thickness: 1 x 12.5 mm
2. Profile e.g. Norgips CD 60 of the main layer, minimum thickness: 0.55 mm
3. Profile e.g. Norgips CD 60 of the loadbearing layer, minimum thickness: 0.55 mm
4. Profile e.g. Norgips UD 30, minimum thickness: 0.55 mm
5. Hanger e.g. Norgips ES 60 or Norgips ES 60 plus
6. Sheet steel screw with self-drilling ending e.g. Norgips 3.9 mm x 11 mm or Norgips 3.5 mm x 9.5 mm (4 screws per hanger ES or ES plus)
7. Sheet steel screw e.g. Norgips 3.5 x 25 mm placed every 17 cm
8. Sealing tape e.g. Norgips, width: 30 mm (recommended)
9. Cross connector e.g. Norgips for profiles CD 60
10. Gypsum filler e.g. Norgips Start, Norgips Super Filler or Norgips Start & Finish (Norgips Light Ready Mix)
11. Mechanical connector, e.g.: wall plug, dowel of the minimum dimensions of $\varnothing 6 \times 40$ mm
12. Mechanical connector, e.g.: screw, steel dowel of the minimum dimensions of $\varnothing 6 \times 60$ mm

Figure 6 Cross and longitudinal sections of the suspended ceiling – two level cross construction

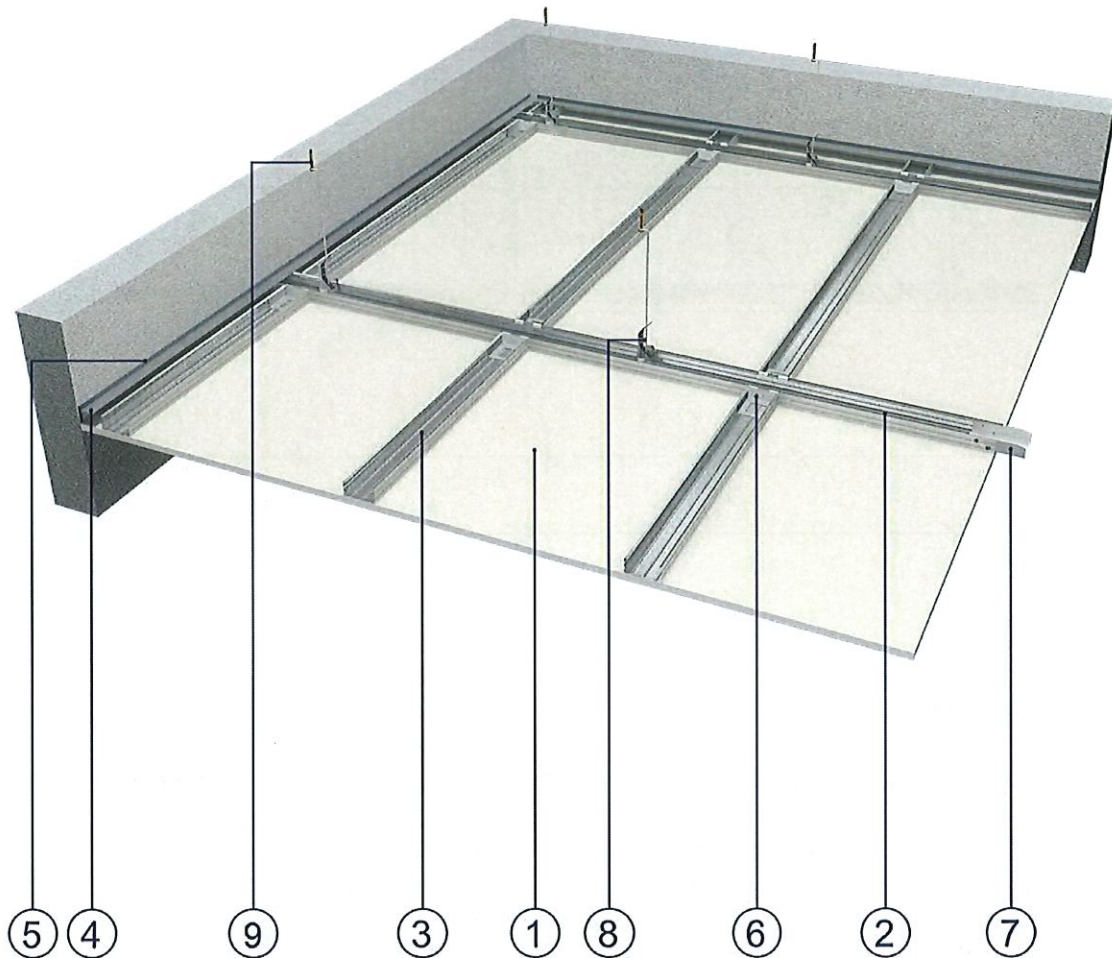

Elements of the ceiling

1. Gypsum plasterboards Norgips GKF type DF or Norgips GKFI type DFH2 or Norgips Acoustic Super type DFH2IRE, thickness: 12.5 mm
2. Profiles e.g. Norgips CD 60 of the main layer, minimum thickness: 0.55 mm, placed maximally every 120 cm
3. Profiles e.g. Norgips CD 60 of the loadbearing layer, minimum thickness: 0.55 mm, placed maximally every 40 cm
4. Profile e.g. Norgips UD 30, minimum thickness: 0.55 mm
5. Sealing tape, width: 30 mm (recommended)
6. Single-sided cross connector e.g. Norgips for profiles CD 60 connected with profiles CD 60 by means of sheet steel screws with self-drilling endings e.g. Norgips 3.9 mm x 11 mm or Norgips 3.5 mm x 9.5 mm (4 screws per connection)
7. Longitudinal connector e.g. Norgips for profiles CD 60
8. Hanger e.g. Norgips: rotating hanger with spring or rotating hanger with nonius or hanger ES 60 or hanger ES 60 plus placed maximally every 70 cm
9. Mechanical connector, e.g.: screw, steel dowel of the minimum dimensions of $\varnothing 6 \times 60$ mm

Figure 7 View of the suspended ceiling – one level cross construction

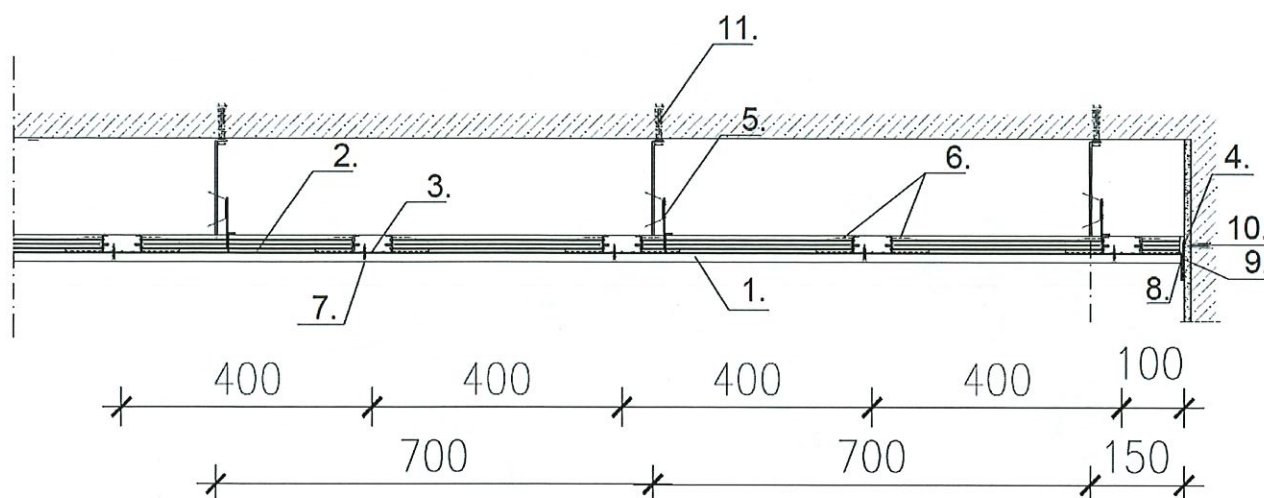

Elements of the ceiling

1. Gypsum plasterboards Norgips GKF type DF or Norgips GKFI type DFH2 or Norgips Acoustic Super type DFH2IRE, thickness: 12.5 mm
2. Profile e.g. Norgips CD 60 of the main layer, minimum thickness: 0.55 mm
3. Profile e.g. Norgips CD 60 of the loadbearing layer, minimum thickness: 0.55 mm
4. Profile e.g. Norgips UD 30, minimum thickness: 0.55 mm
5. Hanger e.g. Norgips: rotating hanger with spring or rotating hanger with nonius or hanger ES 60 or hanger ES 60 plus
6. Single-sided cross connectors connected with profiles CD 60 by means of sheet steel screws with self-drilling endings e.g. Norgips 3.9 mm x 11 mm or Norgips 3.5 mm x 9.5 mm (4 screws per connector)
7. Sheet steel screw e.g. Norgips 3.5 x 25 mm placed every 17 cm
8. Sealing tape e.g. Norgips, width: 30 mm (recommended)
9. Gypsum filler e.g. Norgips Start, Norgips Super Filler or Norgips Start & Finish (Norgips Light Ready Mix)
10. Mechanical connector, e.g.: wall plug, dowel of the minimum dimensions of $\varnothing 6 \times 40$ mm
11. Mechanical connector, e.g.: screw, steel dowel of the minimum dimensions of $\varnothing 6 \times 60$ mm

Figure 8 Cross and longitudinal sections of the suspended ceiling – one level cross construction

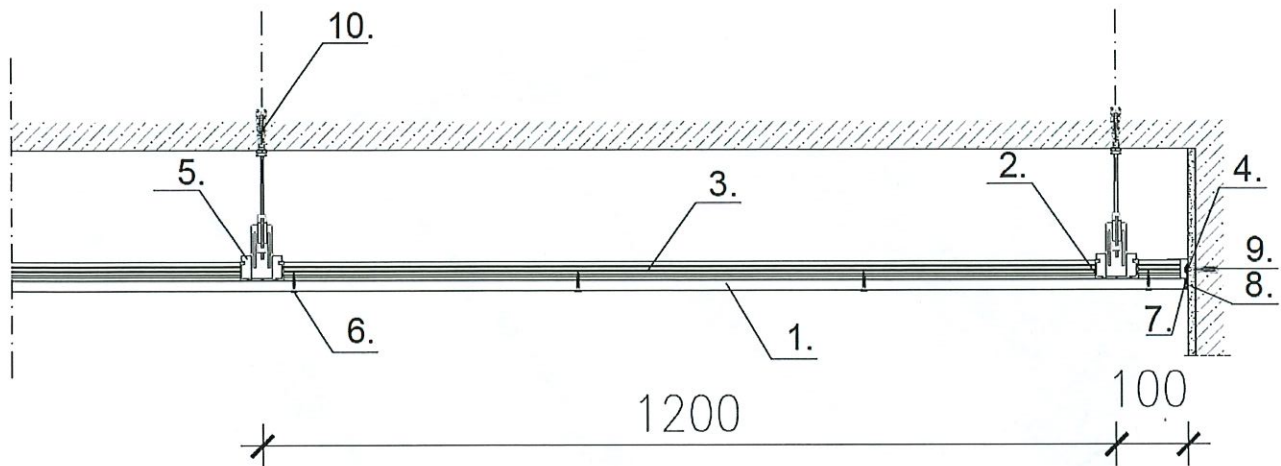

Elements of the ceiling

1. Gypsum plasterboards Norgips GKF type DF or Norgips GKFI type DFH2 or Norgips Acoustic Super type DFH2IRE, thickness: 12.5 mm
2. Profile e.g. Norgips CD 60 of the main layer, minimum thickness: 0.55 mm
3. Profile e.g. Norgips CD 60 of the loadbearing layer, minimum thickness: 0.55 mm
4. Profile e.g. Norgips UD 30, minimum thickness: 0.55 mm
5. Hanger e.g. Norgips: rotating hanger with spring or rotating hanger with nonius or hanger ES 60 or hanger ES 60 plus
6. Sheet steel screw e.g. Norgips 3.5 x 25 mm placed every 17 cm
7. Sealing tape e.g. Norgips, width: 30 mm (recommended)
8. Gypsum filler e.g. Norgips Start, Norgips Super Filler or Norgips Start & Finish (Norgips Light Ready Mix)
9. Mechanical connector, e.g.: wall plug, dowel of the minimum dimensions of $\varnothing 6 \times 40$ mm
10. Mechanical connector, e.g.: screw, steel dowel of the minimum dimensions of $\varnothing 6 \times 60$ mm

Figure 9 Cross and longitudinal sections of the suspended ceiling – one level cross construction

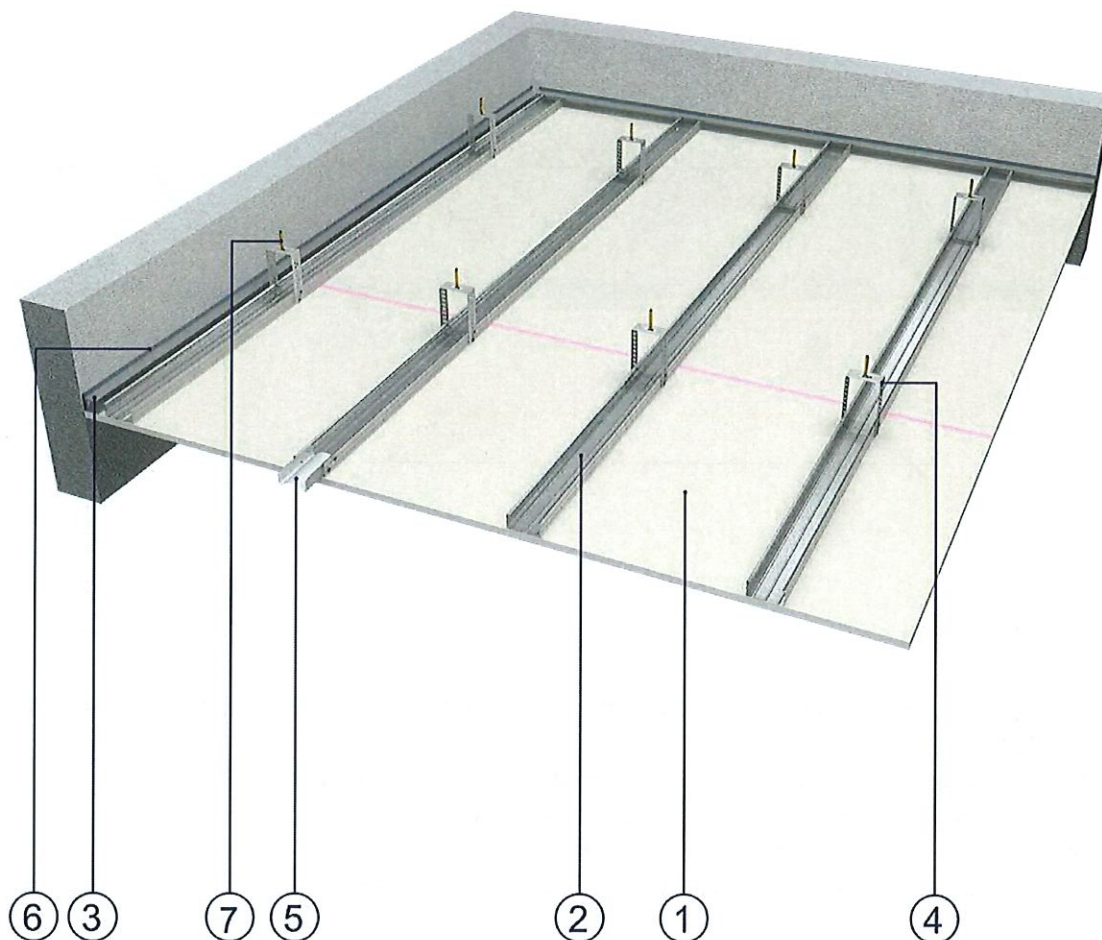

Elements of the lining

1. Gypsum plasterboards Norgips GKF type DF or Norgips GKFI type DFH2 or Norgips Acoustic Super type DFH2IRE, thickness: 12.5 mm
2. Profile e.g. Norgips CD 60, minimum thickness: 0.55 mm
3. Profile e.g. Norgips UD 30, minimum thickness: 0.55 mm
4. Hanger e.g. Norgips ES 60/75, 60/125 or ES plus 60/60, 60/120
5. Longitudinal connector for profiles CD 60
6. Sealing tape, width: 30 mm (recommended)
7. Mechanical connector, e.g.: screw, steel dowel of the minimum dimensions of $\varnothing 6 \times 60$ mm

Figure 10 View of the ceiling lining suspended on hangers ES or ES 60 plus

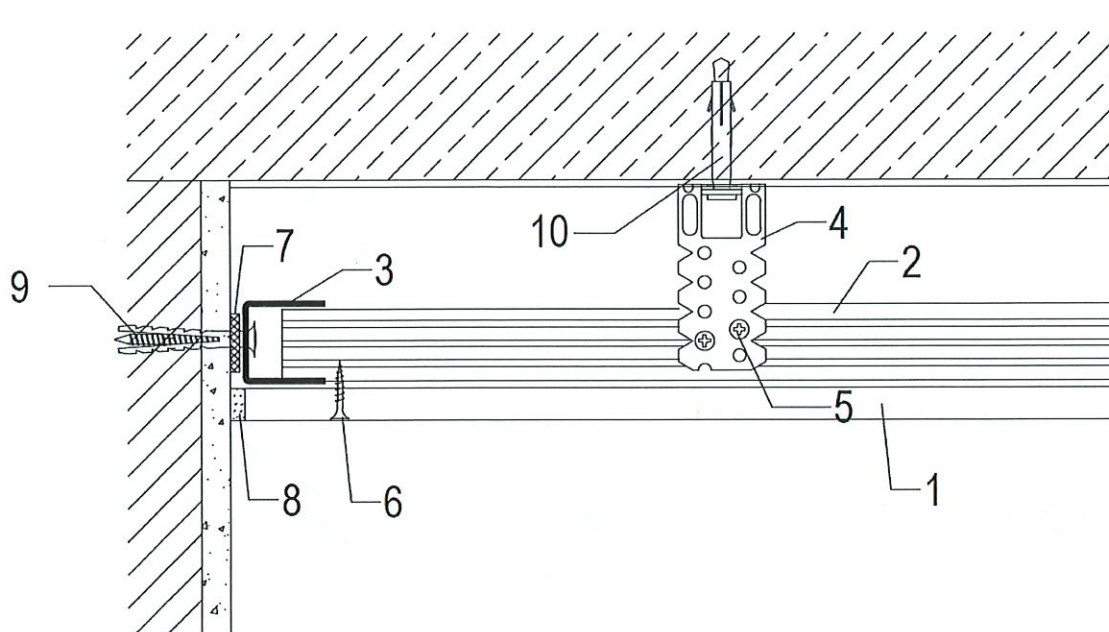

Elements of the lining

1. Gypsum plasterboards Norgips GKF type DF or Norgips GKFI type DFH2 or Norgips Acoustic Super type DFH2IRE, thickness: 12.5 mm
2. Profile e.g. Norgips CD 60, minimum thickness: 0.55 mm
3. Profile e.g. Norgips UD 30, minimum thickness: 0.55 mm
4. Hanger e.g. Norgips ES 60 or Norgips ES 60 plus
5. Sheet steel screw with self-drilling ending Norgips 3.9 mm x 11 mm or Norgips 3.5 mm x 9.5 mm (4 screws per hanger ES or ES plus)
6. Sheet steel screw e.g. Norgips 3.5 x 25 mm placed every 17 cm
7. Sealing tape e.g. Norgips, width: 30 mm (recommended)
8. Gypsum filler e.g. Norgips Start, Norgips Super or Norgips Start & Finish (Norgips Light Ready Mix)
9. Mechanical connector, e.g.: wall plug, dowel of the minimum dimensions of $\varnothing 6 \times 40$ mm
10. Mechanical connector, e.g.: screw, steel dowel of the minimum dimensions of $\varnothing 6 \times 60$ mm

Figure 11 Longitudinal section of the ceiling lining suspended on hangers ES or ES plus

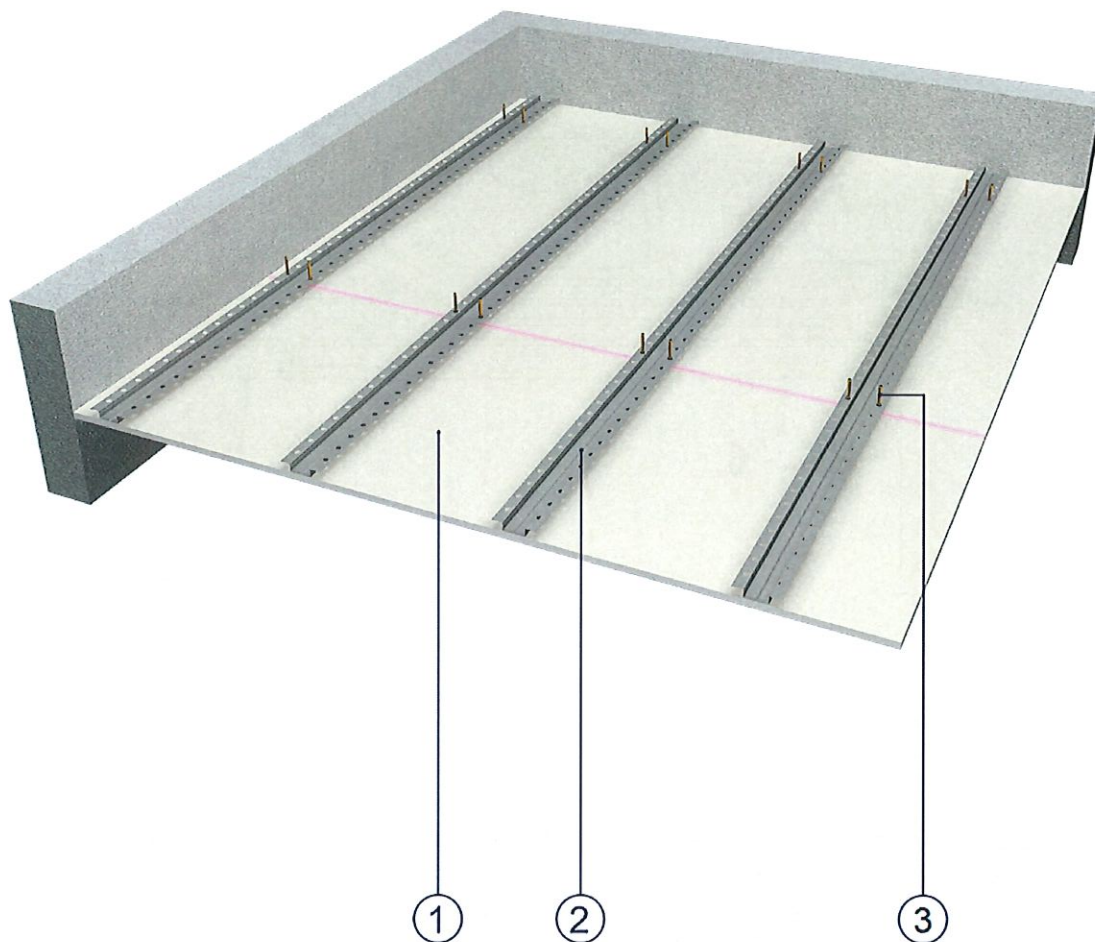

Elements of the lining

1. Gypsum plasterboards Norgips GKF type DF or Norgips GKFI type DFH2 or Norgips Acoustic Super type DFH2IRE, thickness: 12.5 mm
2. Hat profile e.g. Norgips, minimum thickness: 0.55 mm
3. Mechanical connector, e.g.: screw, steel dowel of the minimum dimensions of $\varnothing 6 \times 60$ mm

Figure 12 View of the ceiling lining suspended on hat profiles

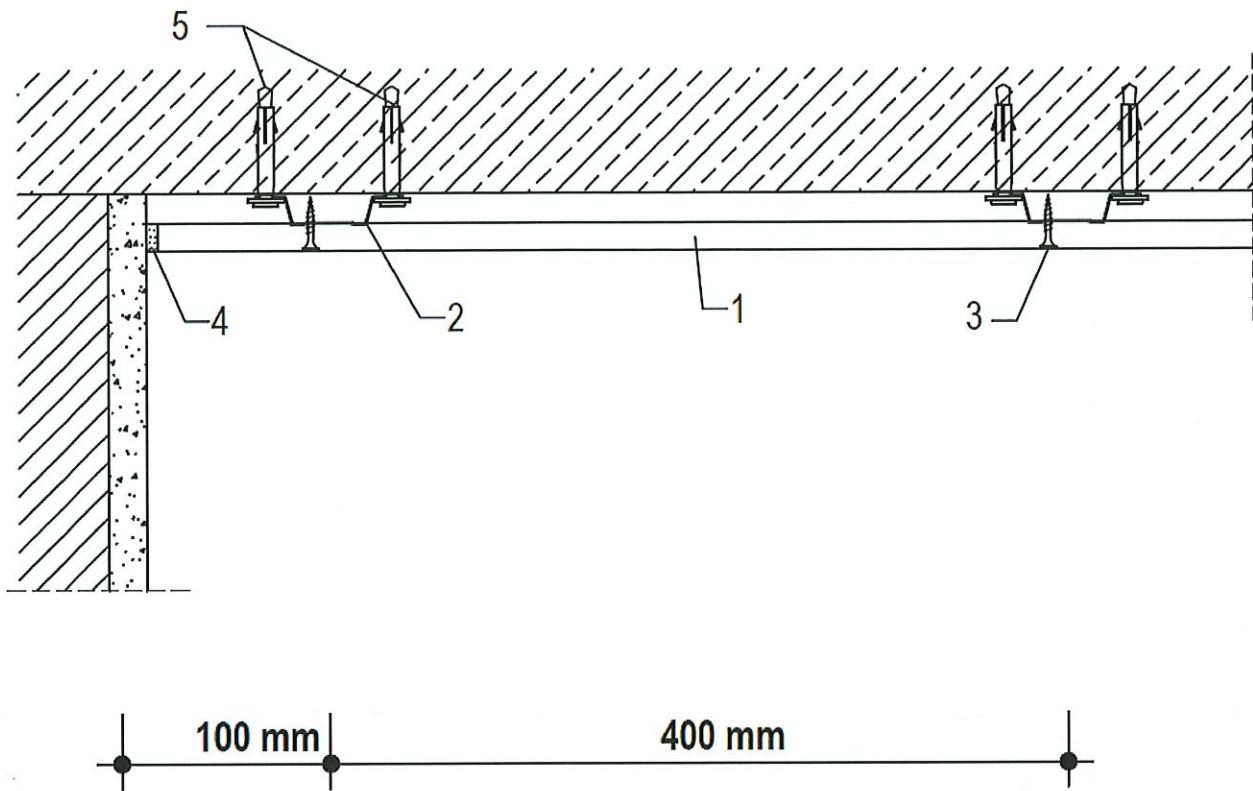

Elements of the lining

1. Gypsum plasterboards Norgips GKF type DF or Norgips GKFI type DFH2 or Norgips Acoustic Super type DFH2IRE, thickness: 12.5 mm
2. Hat profile e.g. Norgips, minimum thickness: 0.55 mm
3. Sheet steel screw e.g. Norgips 3.5 x 25 mm placed every 17 cm
4. Gypsum filler e.g. Norgips Start, Norgips Super Filler or Norgips Start & Finish (Norgips Light Ready Mix)
5. Mechanical connector, e.g.: screw, steel dowel of the minimum dimensions of $\varnothing 6 \times 60$ mm

Figure 13 Cross section of the ceiling lining suspended on hat profiles

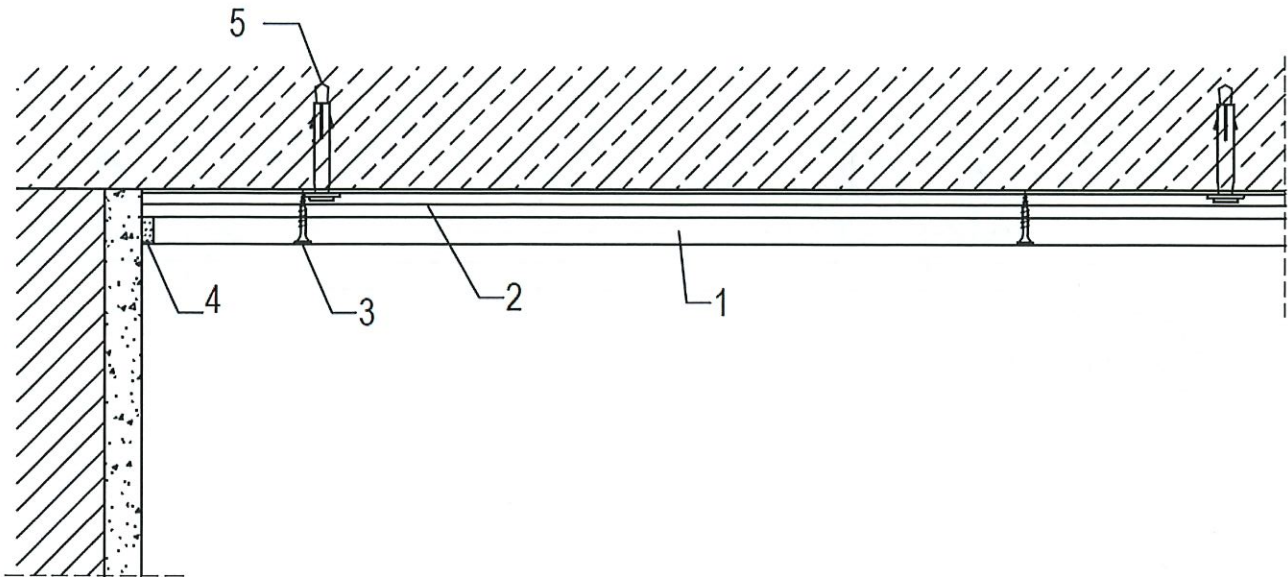

Elements of the lining

1. Gypsum plasterboards Norgips GKF type DF or Norgips GKFI type DFH2 or Norgips Acoustic Super type DFH2IRE, thickness: 12.5 mm
2. Hat profile e.g. Norgips, minimum thickness: 0.55 mm
3. Sheet steel screw e.g. Norgips 3.5 x 25 mm placed every 17 cm
4. Gypsum filler e.g. Norgips Start, Norgips Super Filler or Norgips Start & Finish (Norgips Light Ready Mix)
5. Mechanical connector, e.g.: screw, steel dowel of the minimum dimensions of $\varnothing 6 \times 60$ mm

Figure 14 Longitudinal section of the ceiling lining suspended on hat profiles

GRYFITLAB Sp. z o.o.
Zespół Laboratoriów
Badawczych Gryfitlab
ul. Prosta 2, Łozienica
72-100 GOLENIÓW

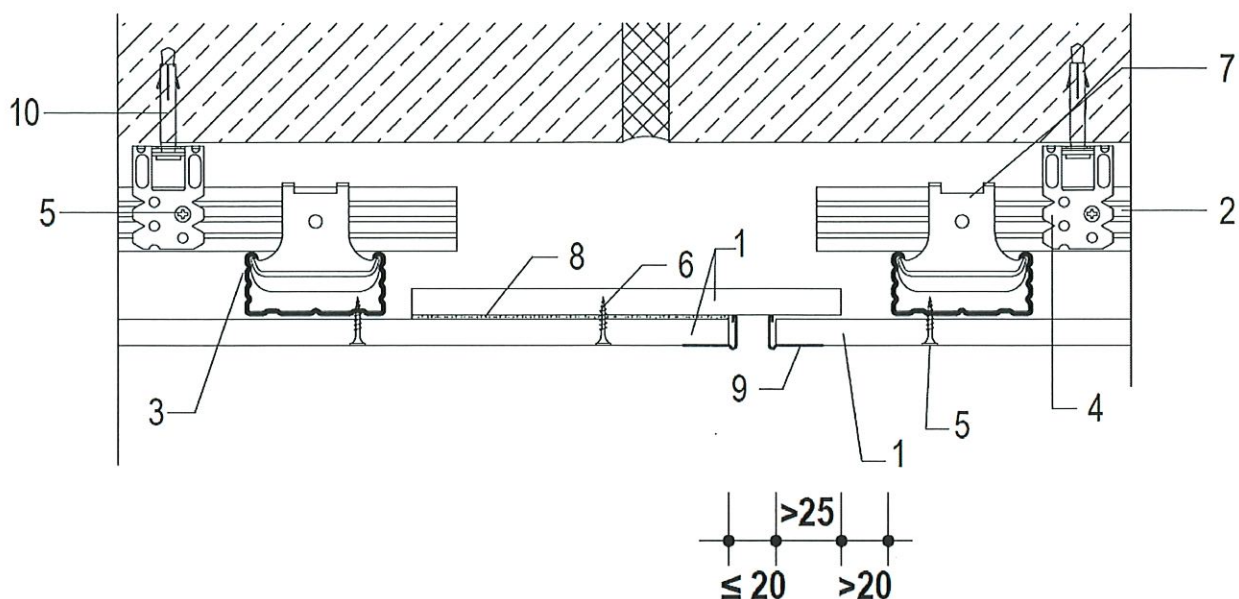

Elements of the expansion joint

1. Gypsum plasterboards Norgips GKF type DF or Norgips GKFI type DFH2 or Norgips Acoustic Super type DFH2IRE, thickness: 12.5 mm
2. Profile e.g. Norgips CD 60 of the main layer, minimum thickness: 0.55 mm
3. Profile e.g. Norgips CD 60 of the loadbearing layer, minimum thickness: 0.55 mm
4. Hanger e.g. Norgips: hanger ES 60 or hanger ES 60 plus or rotating hanger with spring or rotating hanger with nonius
5. Sheet steel screw with self-drilling ending e.g. Norgips 3.9 mm x 11 mm or Norgips 3.5 mm x 9.5 mm (4 screws per hanger ES or ES plus)
6. Sheet steel screw e.g. Norgips 3.5 x 25 mm placed every 17 cm
7. Cross connector e.g. Norgips for profiles CD 60
8. Gypsum filler e.g. Norgips Start, Norgips Super Filler or Norgips Start & Finish (Norgips Light Ready Mix)
9. Protection corner

Figure 15 Suspended ceiling – expansion joints