

SYSTEM DATASHEET

Partition wall SD - 1x15 GKF DF/CW 100 W

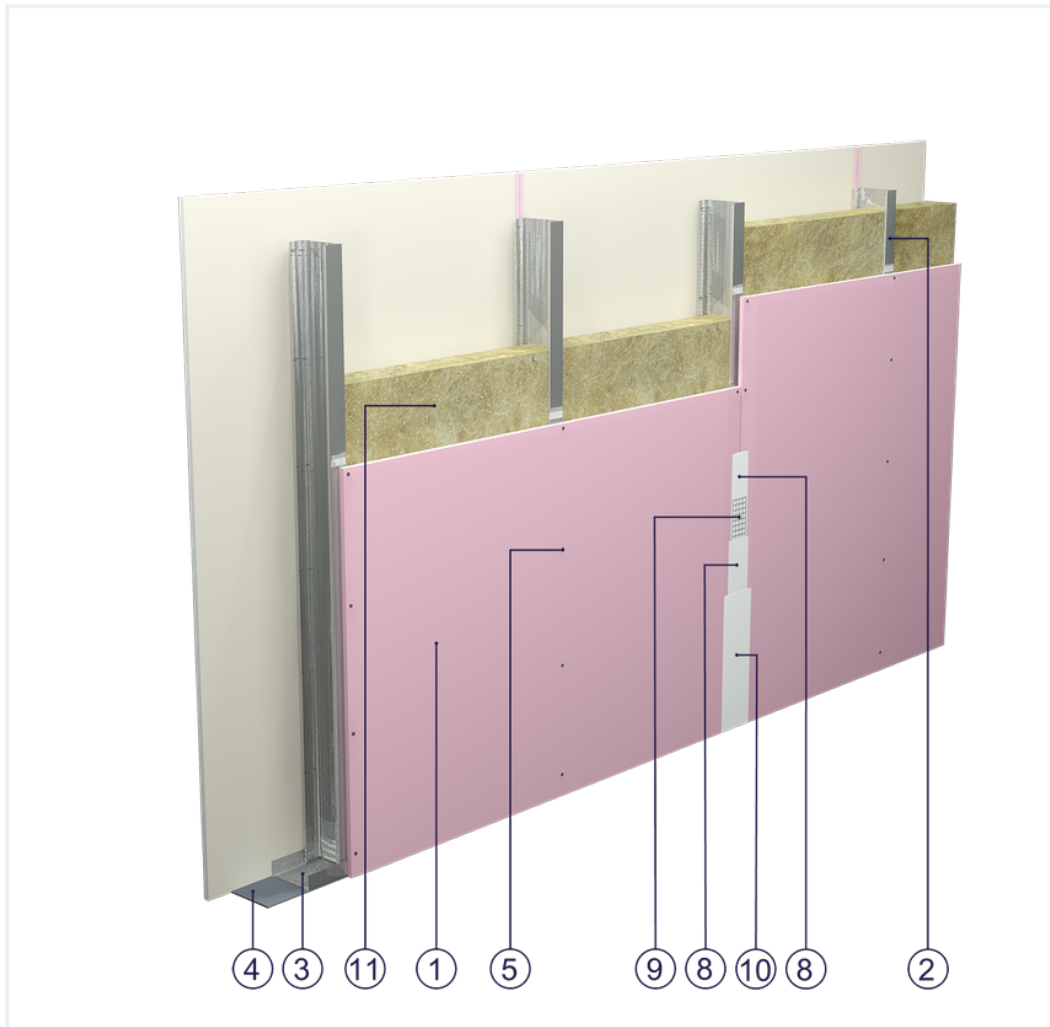



on a CW 100 and UW 100 profile structure with a single sheathing of DF type GKF boards with a thickness of 15 mm with mineral wool filling



Partition wall components

1. Norgips S GKF type DF gypsum plasterboard , thickness: 15 mm
2. Norgips CW 100 profiles, max. axial spacing every 60 cm
3. Norgips UW 100 profiles mounted on horizontal load-bearing elements
4. Norgips sealing tape, width 100 mm
5. Norgips 3.5 x 25 mm sheet metal screws, max. spacing every 25 cm
6. Fastening pins, min. Ø 6 x 40 mm, max. spacing every 80 cm
7. Openings in studs for installation wires
8. Norgips Start & Finish ready-made joint compound or Norgips Start gypsum joint compound
9. Norgips reinforcing tape
10. Ready-made joint compound Norgips Extra Finish, ready-made joint compound Norgips Start & Finish, gypsum joint compound Norgips Finish
11. Mineral wool

Technical data

 Fire resistance class EI 60 ($h_{\max}=5.0$ m) ^{1) 2)}	 Max height 5.8 m ¹⁾
 Wall mass 31 kg/m ² ³⁾	 Acoustic insulation $R_W=47$ dB $R_{A1}=45$ dB

The above-mentioned parameters apply to a partition made of sheet metal profiles with a thickness of 0.55 and 0.6 mm.

- 1) The stated heights apply to constructions with a profile spacing of 600 mm. When a structure with profiles spaced every 300 or 400 mm is used, the permissible wall height increases. Contact system provider representatives for details. The stated heights apply to rooms where only a few persons are present simultaneously (e.g. rooms in flats, hotels, hospitals). In rooms where a large number of persons are present simultaneously (e.g. conference rooms, classrooms, lecture halls), the permissible height is 4.9 m.
- 2) Based on classification no. LBO-759-K/22 for 100 mm rock wool
- 3) The weight specified does not include the insulation material weight.

Standard

★ BASIC

Provides a lightweight stable building with basic fire resistance. A robust and cost-effective solution.

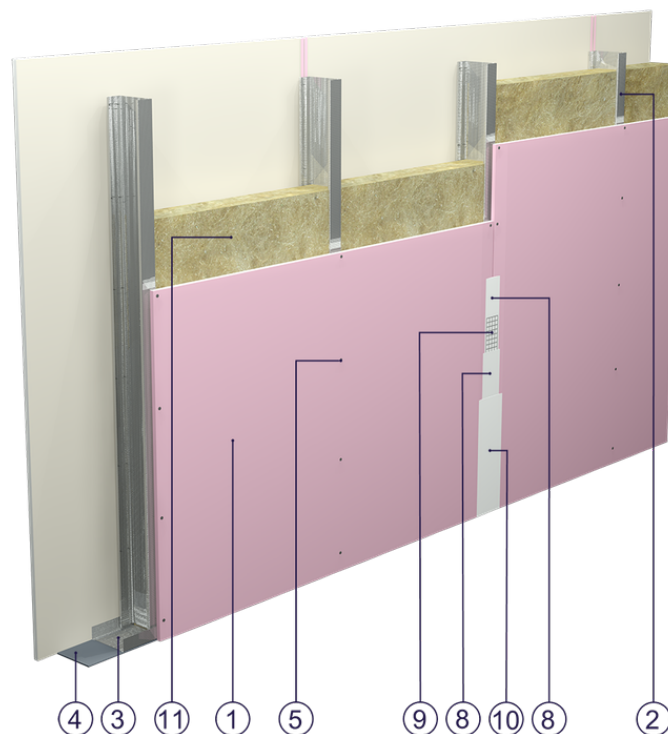

Fig. 1. Partition wall view

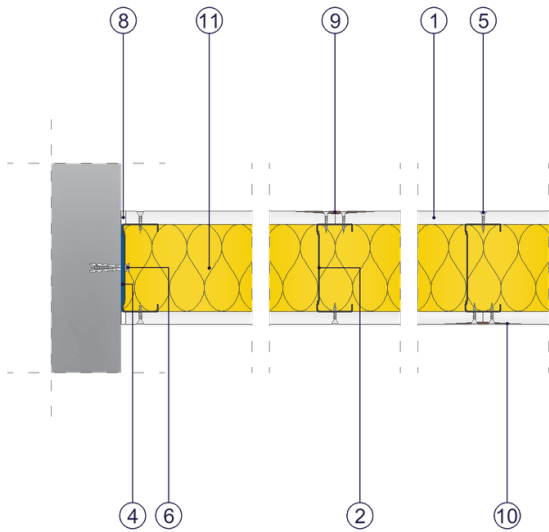

Fig. 2. Partition wall horizontal section

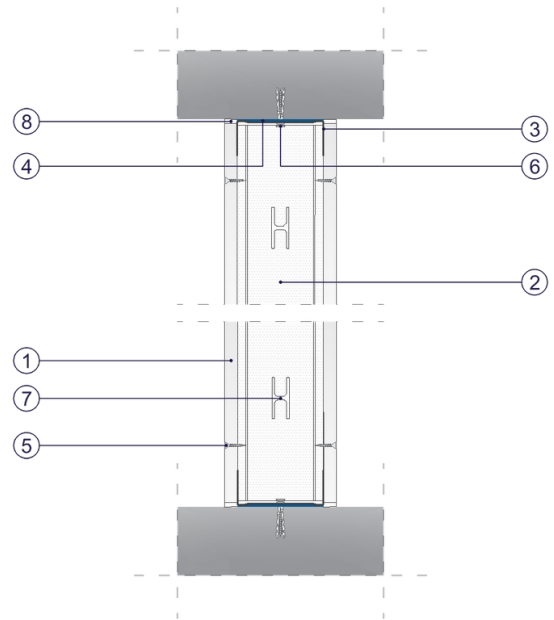

Fig. 3. Partition wall vertical section